RR 2T ENDURO 2014

250/300cc

RR 2T ENDURO RACING 2014

250/300cc

CATALOGO PARTI DI RICAMBIO
CATALOGUE OF SPARE PARTS
CATALOGUE PIECES DE RECHANGE
ERSATZTEILKATALOG
CATALOGO DE PIEZAS DE REPUESTO



TAV.01 Carter completo - Crankcase, assy - Carter complet - Kurbelwellengehäuse, KPL. - Carter completo

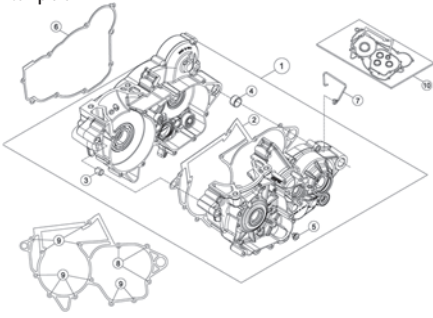

Pag. 6

TAV.01A Coperchio frizione - Clutch cover - Couvercle d'embrague - Kupplungsdeckel - Tapa embrague

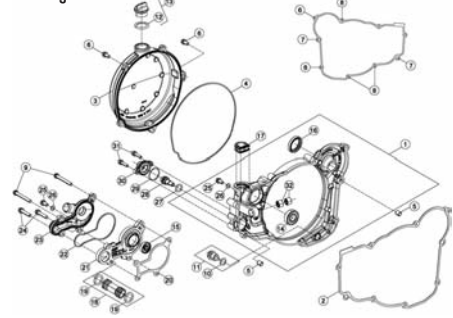

Pag. 8

TAV.01B Collettore aspirazione - Intake manifold - Collecteur aspiration - Ansaugstutzen - Colector aspiración

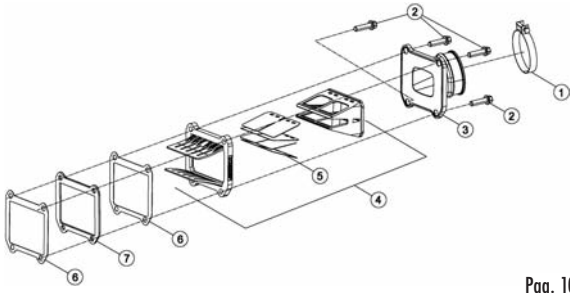

Pag. 10

TAV.02 Albero motore - Crankshaft - Vilebrequin - Kurbelwelle - Cigüeñal

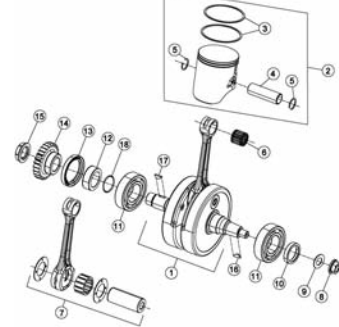

Pag. 11

TAV.03 Frizione - Clutch - Embrayage - Kupplung - Embrague

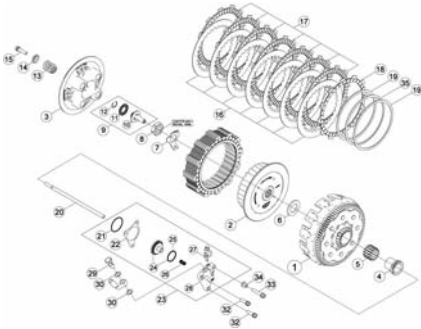

Pag. 12

TAV.04A Albero primario - Main shaft - Arbre primaire - Hauptwelle - Arbol primario

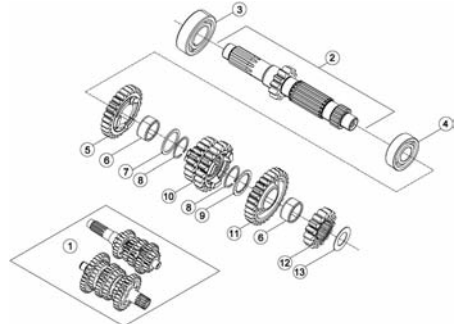

Pag. 14

TAV.04B Albero secondario - Counter shaft - Arbre secondaire - Nebentriebewelle - Eje secundario

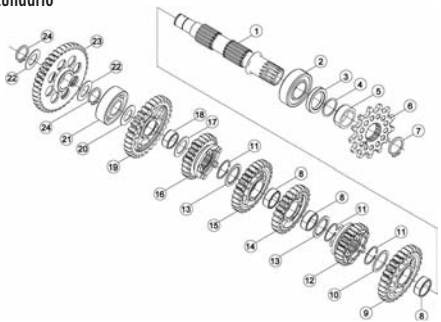

Pag. 15

TAV.05 Comando cambio - Gear shift control - Commande changement de vitesse - Chaltung - Mando cambio

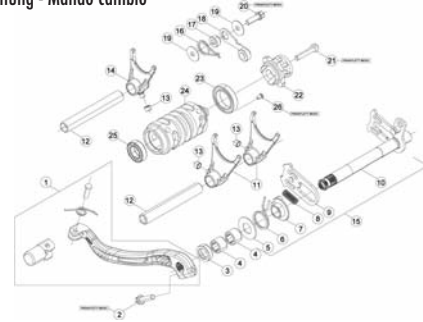

Pag. 16

TAV.06 Avviamento a pedale - Kickstarter - Dé marrage à pedal - Pedalstart - Arranque a pedal

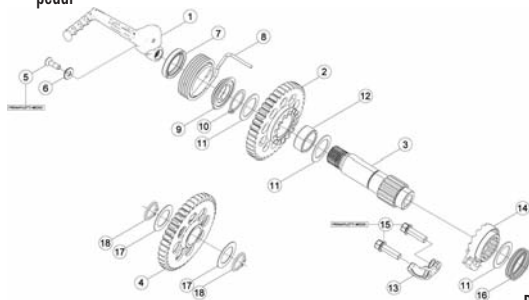

Pag. 17

TAV.07 Avviamento elettrico - Electric starter - Dé marrage électrique - Elektrischer start - Arranque eléctrico

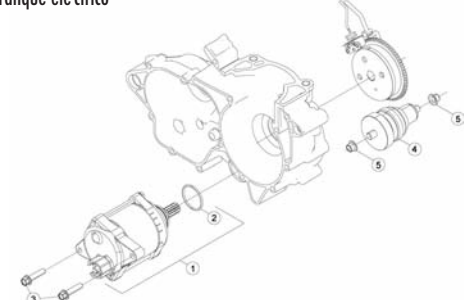

Pag. 18

TAV.09 Sistema di raffreddamento - Cooling system - Dispositifs de refroidissement - Kühlungssystem - Sistema de enfriamiento



Pag. 20

TAV.10 Gruppo accensione elettronica - Electronic ignition assy. - Groupe allumage électronique - Elektronischezündung gruppe - Grupo encendido electrónico

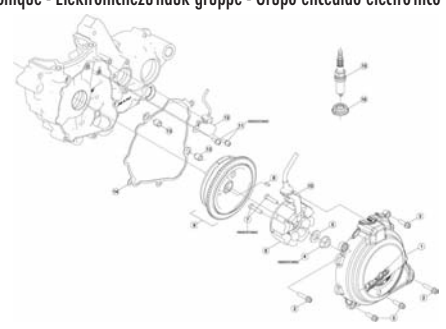

Pag. 22

TAV.11 Cilindro completo - Cylinder, assy - Cylindre complet - Zylinder, KPL - Cilindro completo

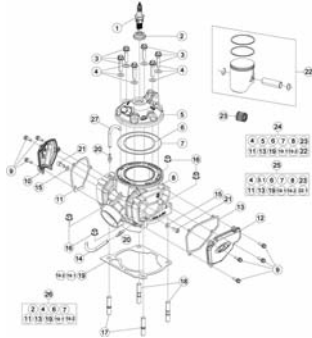

Pag. 24

TAV.12 Carburatore - Carburettor - Carburateur - Vergaser - Carburador

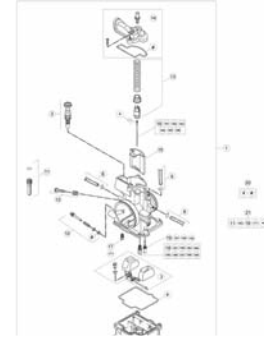

Pag. 26

TAV.14 Attrezzatura specifica - Special tools - Outillage spéciale - Spezialwerkzeug - Utillaje específico

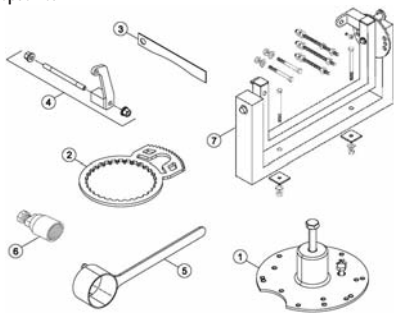

Pag. 28

TAV.31 Telaio - Frame - Chassis - Rahmen - Chasis

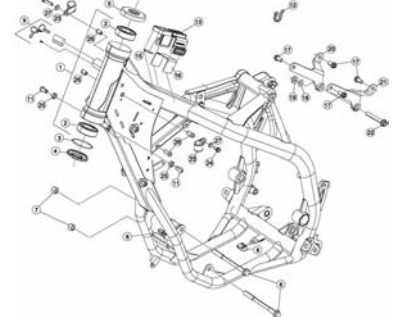

Pag. 30

TAV.32 Accessori telaio - Frame accessories - Accessoires chassis - Rahmenzubehör - Accesorios Chasis

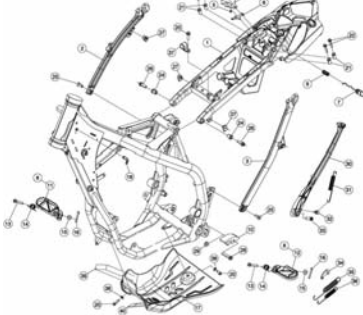

Pag. 32

TAV.33A Ammortizzatore posteriore - Rear damper - Amortisseur arrière - Hinterer Stoßdämpfer - Amortiguador posterior

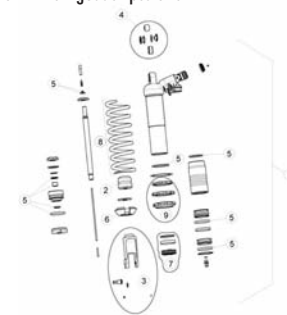

Pag. 34

TAV.33B Forcellone posteriore - Rear fork - Fourche arrière - Hinterradschwinge - Horquilla posterior

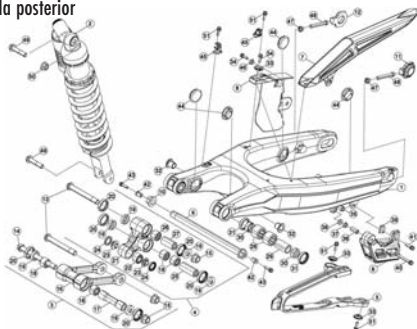

Pag. 36

TAV.34 Forcella anteriore - Front fork - Fourche AV - Vorderradgabel - Horquilla delantera RACING

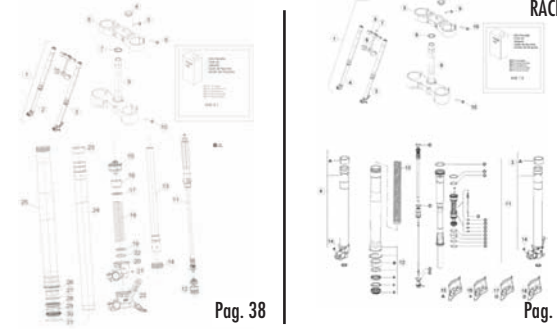

Pag. 38

Pag. 40

TAV.35 Comandi-Manubrio - Controls-Handlebars - Commandes-Guidon - Bedienungselemente-Lenker - Mandos-Manillar

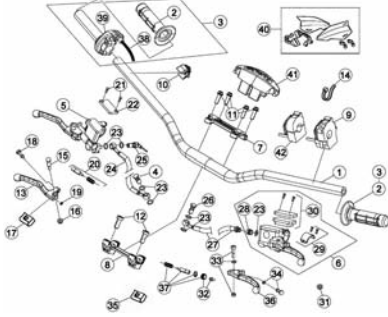

Pag. 42

TAV.36 Impianto freni idraulici - Hydraulic brakes system - Installation des freins hydrauliques - Hidraulischebremse anlage - instalaci3n freno hidr3ulico



Pag. 44

TAV.37A Gruppo scarico (omologato) - Exhaust system (homologated) - Echappement (homologu3) - Auspuffanlage (homologierten) - Grupo escape (homologado)

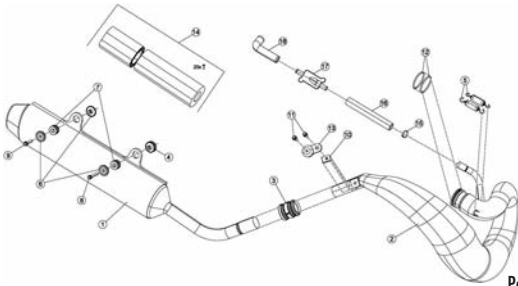

Pag. 46

TAV.37B Gruppo scarico (gara) - Exhaust system (race) - Echappement (course) - Auspuffanlage (rennen) - Grupo escape (carrera)

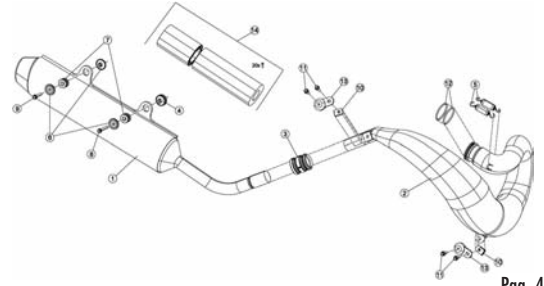

Pag. 47

TAV.38 Scatola filtro - Filter box - Boi tier du filtre - Sicherungskasten - Caja del filtro

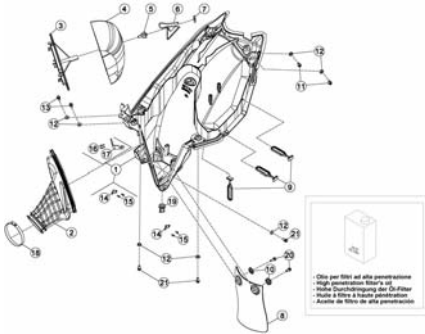

Pag. 48

TAV.39 Impianto di raffreddamento - Installation de refroidissement - Installation de refroidissement - K3hlsystem - Instalaci3n de enfriamiento

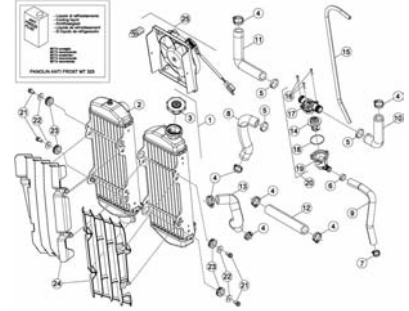

Pag. 49

TAV.40 Impianto elettrico - Electrical equipment - Installation electrique - Elektrische anlage - Instalaci3n electrica

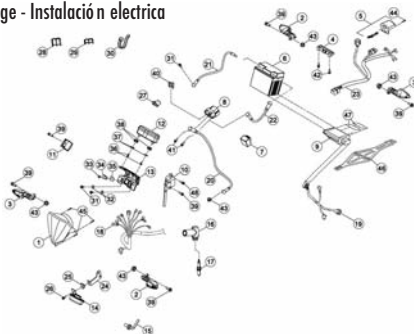

Pag. 50

TAV.41 Ruota anteriore - Front wheel - Roue AV. - Vorderrad - Rueda delantera

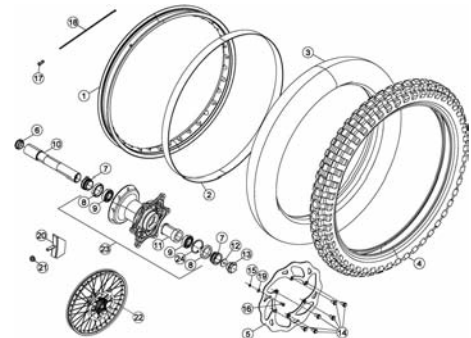

Pag. 52

TAV.42 Ruota posteriore - Rear wheel - Roue AR. - Hinterrad - Rueda trasera

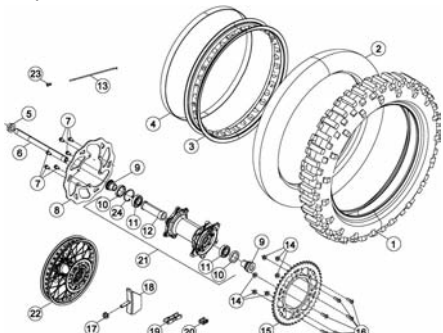

Pag. 53

TAV.43A Carenature-Parafanghi - Mudguards - Carenages-Gardeboues - Verkleidungen-Koffl3geln - Carenados-Guardabarros

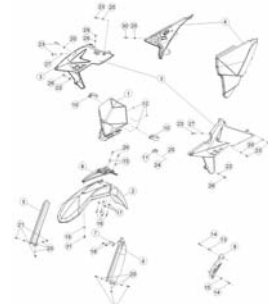

Pag. 54

TAV.43B Carenature-Serbatoio-Sella - Fairings-Tank-Saddle - Carenages-Reservoir-Selle -
Verkleidungen-Tank-Sattel - Carenados-Deposito-Sillin



Pag. 56

TAV.44 Attrezzatura specifica - Special tools - Outillage spéciale - Spezialwerkzeug -
Utillaje específico

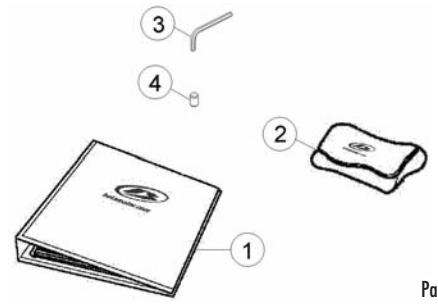

Pag. 56

Tav.01A

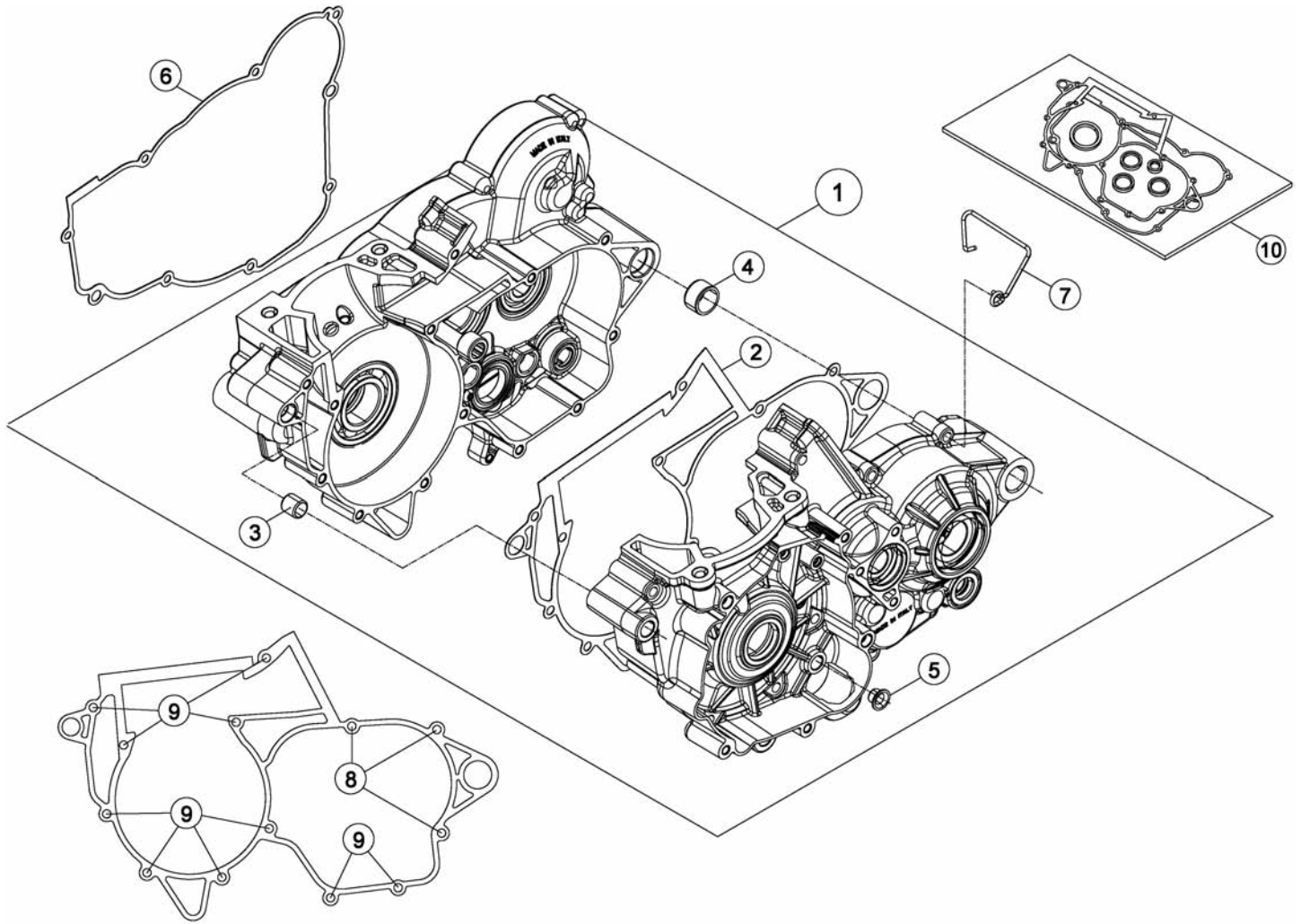

Tav.01A

Pos Loc Pos Ps Pos	Numero Number Numéro Número Nummer	Q.tà Q.ty Q.té M.ge C.ad	Nota Note Note Nota Anm.	Descrizione	Description	Désignation	Beschreibung	Descripcìon
1	026010008 000	1		Carter motore	Crankcase assy	Carter moteur complet	Kurbelgehäuse, kompl.	Carter motor completo
2	026010030 000	1		Guarnizione carter	Crankcase gasket	Joint carter	Dichtung Kurbelwellengehäuse	Junta cárter
3	1641500 000	1		Grano di riferimento	Dowel	Repère	Passtift	Centraje
4	006010120 000	1		Grano di riferimento 17x21.12	Dowel 17x21.12	Repère 17x21.12	Passtift 17x21.12	Centraje 17x21.12
5	C03020010 000	1		Boccola 8x10x8	Bush 8x10x8	Moyeu 8x10x8	Büchse 8x10x8	Buje 8x10x8
6	026010040 000	1		Guarnizione coperchio frizione	Clutch cover gasket	Joint couvercle embrayage	Dichtung Kupplungabdeckung	Junta tapa embrague
7	006010230 000	1		Passacavo	Grommet	Passe-câble	Kabeldurchgang	Pasacables
8	1150360 000	3		Bullone M6x40	Bolt M6x40	Boulon M6x40	Bolzen M6x40	Tornillo M6x40
9	1105535 000	10		Bullone 6.50 rs ch 8	Bolt 6.50 rs ch 8	Boulon 6.50 rs ch 8	Bolzen 6.50 rs ch 8	Tornillo 6.50 rs ch 8
10	026010128 200	1		Kit guarnizioni	Packings kit	Jeu joints	Dichtungensatz	Grupo juntas



Tav.01B

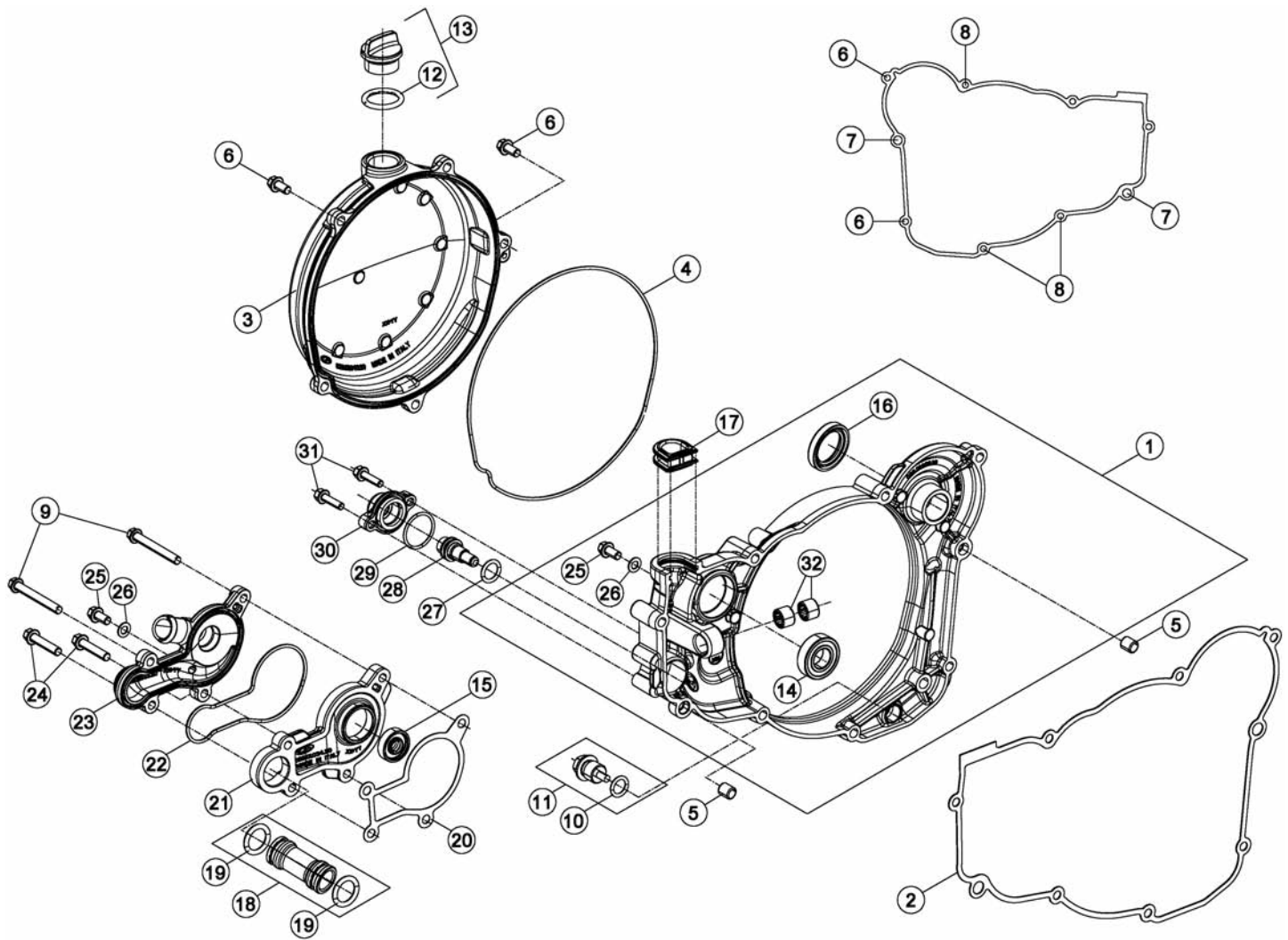

Tav.01B

Pos Loc Pos Ps Pos	Numero Number Número Número	Q.tà Q.ty Q.té M.ge C.ad	Nota Note Note Nota Anm.	Descrizione	Description	Désignation	Beschreibung	Descrìption
1	026010308 052	1		Coperchio frizione interno	Inner clutch cover	Couvercle interne d' embrayage	Innerer Kupplungsdeckel	Tapa interior embrague
2	026010050 000	1		Guarnizione coperchio frizione	Clutch cover gasket	Joint couvercle embrayage	Dichtung Kupplungsabdeckung	Junta tapa embrague
3	026010408 052	1		Coperchio frizione esterno	Outer clutch cover	Couvercle externe d' embrayage	Äußerer Kupplungsdeckel	Tapa exterior embrague
4	026010410 000	1		Guarnizione coperchio frizione	Clutch cover gasket	Joint couvercle embrayage	Dichtung Kupplungsabdeckung	Junta tapa embrague
5	1636500 000	2		Grano 9x7,2x10	Dowel 9x7,2x10	Goujon 9x7,2x10	Stift 9x7,2x10	Clavija 9x7,2x10
6	1149070 000	4		Bullone 6x20 ch rs	Bolt 6x20 ch rs	Boulon 6x20 ch rs	Bolzen 6x20 ch rs	Tornillo 6x20 ch rs
7	1150300 000	2		Bullone 6x30 ch rs	Bolt 6x30 ch rs	Boulon 6x30 ch rs	Bolzen 6x30 ch rs	Tornillo 6x30 ch rs
8	1105535 000	3		Bullone 6.50 rs ch 8	Bolt 6.50 rs ch 8	Boulon 6.50 rs ch 8	Bolzen 6.50 rs ch 8	Tornillo 6.50 rs ch 8
9	1105485 000	2		Bullone M6x60 rs ch 8	Bolt M6x60 rs ch 8	Boulon M6x60 rs ch 8	Bolzen M6x60 rs ch 8	Tornillo M6x60 rs ch 8
10	1066164 000	1		Anello Or 11x2,5 nbr70 sh	O-Ring 11x2,5 nbr70 sh	Bague d' é tanché ité 11x2,5	O-Ring 11x2,5 nbr70 sh	Anillo OR 11x2,5 nbr70 sh
11	006081528 000	1		Tappo scarico olio	Oil exh. plug	Bouchon dech. huile	Oelablassschraube	Tapón de descarga aceite
12	1066340 000	1		Anello OR 16x3	O-Ring 16x3	Bague d' é tanché ité 16x3	O-Ring 16x3	Anillo OR 16x3
13	026010138 000	1		Tappo completo	Complete cap	Bouchon complet	Verschluß komplett	Tapón completo
13	026010138 053	1	RACING	Tappo completo	Complete cap	Bouchon complet	Verschluß komplett	Tapón completo
14	C06010010 000	1		Cuscinetto 15.32.9 6002-2RSH C3	Bearing 15.32.9 6002-2RSH C3	Roulement 15.32.9 6002-2RSH C3	Lager 15.32.9 6002-2RSH C3	Cojinete 15.32.9 6002-2RSH C3
15	1043720 000	1		Anello paraolio 8.24.7	Oil seal 8.24.7	Joint d' é tanché ité 8.24.7	Ölschutzring 8.24.7	Retén de aceite 8.24.7
16	1064490 000	1		Anello paraolio 20x30.5/6	Oil seal 20x30.5/6	Joint d' é tanché ité 20x30.5/6	Ölschutzring 20x30.5/6	Retén de aceite 20x30.5/6
17	026010318 000	1		Guarnizione asta valvola	Valve stem seal	Joint d' etanch. de tige de soupape	Ventilhaftdichtung	Sello de vastago de valvula
18	026010378 000	1		Tubo acqua	Water pipe	Tuyau de l' eau	Kühlflißsigkeitsleitung	Tubo agua
19	C02060520 000	2		Anello OR 17,96x2,62	O-Ring 17,96x2,62	Bague d' é tanché ité 17,96x2,62	O-Ring 17,96x2,62	Anillo OR 17,96x2,62
20	026010360 000	1		Guarnizione pompa acqua	Water pump gasket	Joint pompe eau	Dichtung Wasserpumpe	Empaque bomba agua
21	026010340 000	1		Corpo pompa acqua	Water pump plunger cylinder	Cylindre de plongeur de pompe eau	Wasserpumpengehäuse	Cuepo bomba agua
22	026010350 000	1		Guarnizione pompa acqua	Water pump gasket	Joint pompe eau	Dichtung Wasserpumpe	Empaque bomba agua
23	026010330 000	1		Coperchio pompa acqua	Water pump cover	Couvercle pompe à eau	Wasserpumpendeckel	Tapa bomba agua
24	1150300 000	2		Bullone 6x30 ch rs	Bolt 6x30 ch rs	Boulon 6x30 ch rs	Bolzen 6x30 ch rs	Tornillo 6x30 ch rs
25	1147015 000	2		Bullone M6x12	Bolt M6x12	Boulon M6x12	Bolzen M6x12	Tornillo M6x12
26	2740495 000	2		Rondella in rame 6.11	Copper washer 6.11	Rondelle en cuivre 6.11	Kupfer U.Scheibe 6.11	Arandela de cobre 6.11
27	1066296 000	1		Anello OR 12,37.2,62	O-Ring 12,37.2,62	Bague d' é tanché ité 12,37.2,62	O-Ring 12,37.2,62	Anillo OR 12,37.2,62
28	026090200 000	1		Guida molla	Spring guide	Guide ressort	Federfuehrung	Guia de resorte
29	1066540 000	1		Anello OR 24.2	O-Ring 24.2	Bague d' é tanché ité 24.2	O-Ring 24.2	Anillo OR 24.2
30	026090250 000	1		Coperchio	Cover	Couvercle	Deckel	Tapa
31	1146401 000	1		Bullone M5x20	Bolt M5x20	Boulon M5x20	Bolzen M5x20	Tornillo M5x20
32	1122100 000	2		Boccola a rulli 10.14.10	Roller bearing 10.14.10	Douille à roulements	Rollenbuchse	Caja de grasa de rodillos

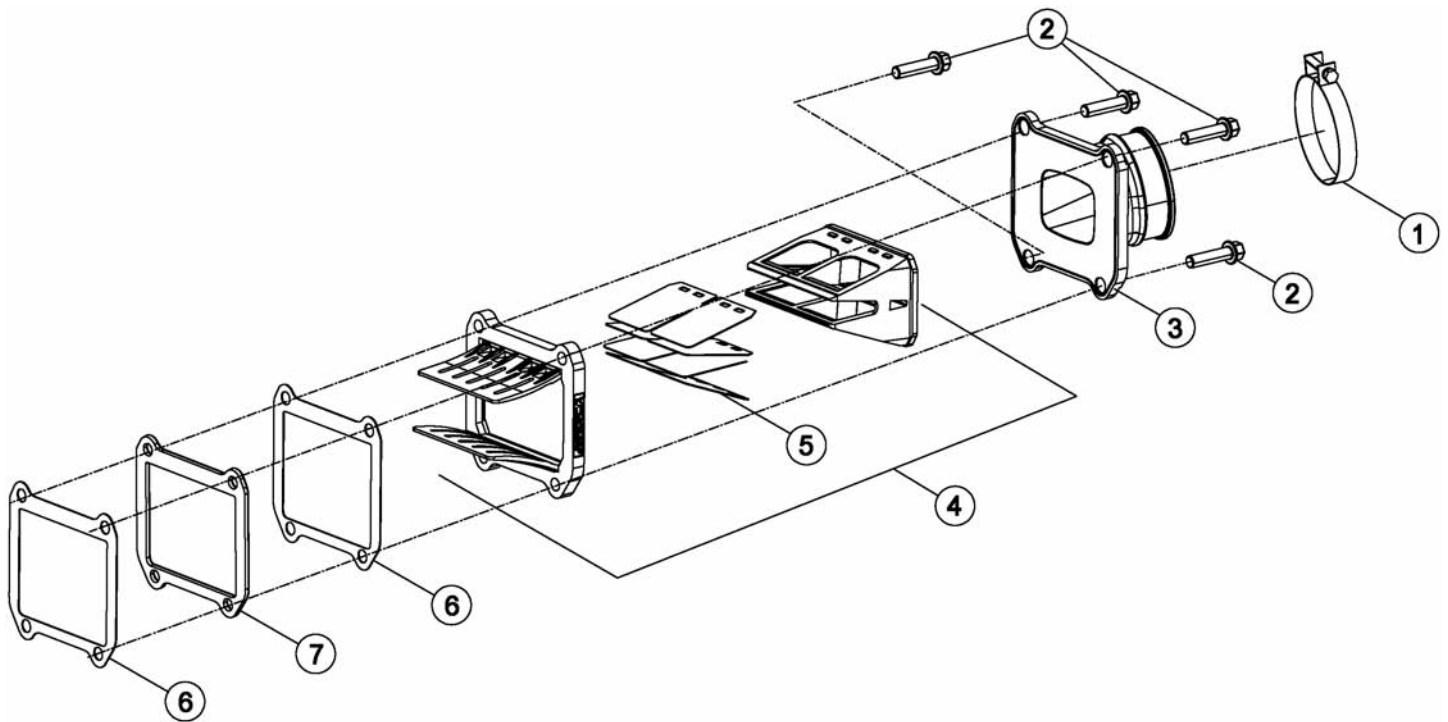

Pos Loc Pos Ps Pos	Numero Number Numéro Número Nummer	Q.tà Q.ty Q.té M.ge C.ad	Nota Note Note Nota Anm.	Descrizione	Description	Dé signation	Beschreibung	Descripció n
1	1514275 000	1		Fascetta 52/12	Clamp 52/12	Collier 52/12	Schelle 52/12	Abrazadera 52/12
2	1150010 000	4	250cc +RACING	Bullone M6x25	Bolt M6x25	Boulon M6x25	Bolzen M6x25	Tornillo M6x25
2	1150030 000	4	300cc	Bullone M6x28	Bolt M6x28	Boulon M6x28	Bolzen M6x28	Tornillo M6x28
3	026010060 000	1		Collettore di aspirazione	Inlet duct	Conduit adm.	Ansaugstutzen	Colector
4	026010078 000	1		Pacco lamellare	Leaf valve	Pyramide clapets	Lamellenpaket	Válvula láminas
5	026010090 000	1		Kit lamelle	Plate kit	Kit lamelle	Plättchenkit	Kit Laminilla
6	026010100 000	1	250cc +RACING	Guarnizione valvola aspirazione	Suction valve gasket	Joint soupape aspir.	Dichtung Einlaßventil	Junta válvula aspiración
6	026010100 000	2	300cc	Guarnizione valvola aspirazione	Suction valve gasket	Joint soupape aspir.	Dichtung Einlaßventil	Junta válvula aspiración
7	026010084 252	1	300cc	Distanziale	Spacer	Entretoise	Distanzstück	Distanciador



Tav.02

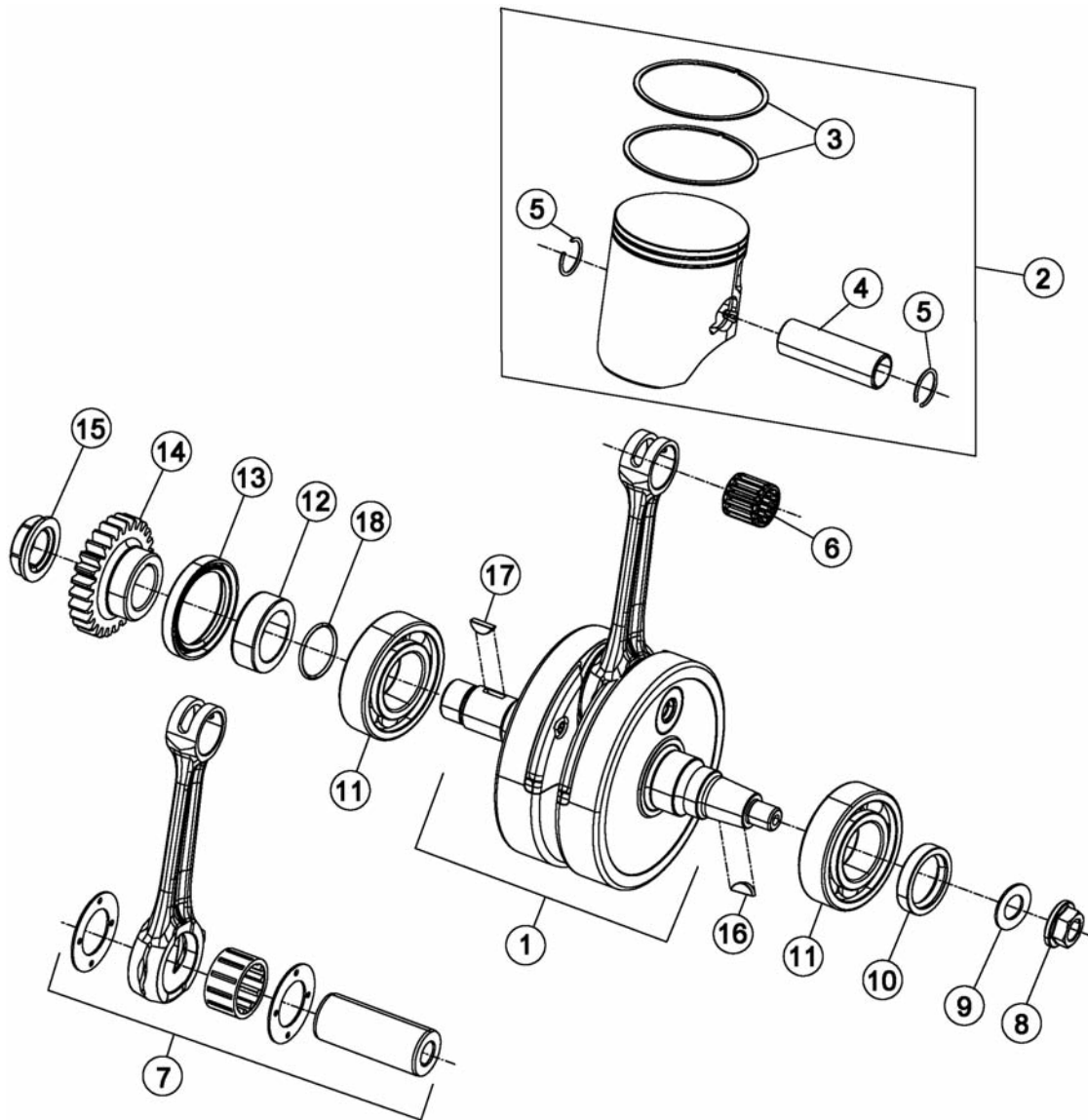

Pos Loc Pos Ps Pos	Numero Number Numéro Número Nummer	Q.tà Q.ty Q.té M.ge C.ad	Nota Note Note Nota Anm.	Descrizione	Description	Dé signation	Beschreibung	Descrìciò n
1	026020008 000	1		Albero motore completo	Crankshaft, assy.	Arbre moteur complet	kurbelwelle, komplett	Cigü eñ al completo
2	026020208 000	1	250cc	Pistone completo 250cc	Piston set 250cc	Piston compl. 250cc	Kolben, kompl. 250cc	Pistón, compl. 250cc
2	026020308 000	1	300cc	Pistone completo 300cc	Piston set 300cc	Piston compl. 300cc	Kolben, kompl. 300cc	Pistón, compl. 300cc
3	026020210 000	2	250cc	Segmento pistone 250cc	Piston ring 250cc	Segment de piston 250cc	Kolbendichtring 250cc	Aro piston 250cc
3	026020310 000	2	300cc	Segmento pistone 300cc	Piston ring 300cc	Segment de piston 300cc	Kolbendichtring 300cc	Aro piston 300cc
4	026020230 000	1		Spinotto	Pin	Axe	Zapfen	Eje
5	1042600 000	2		Anello ferma spinotto	Piston pin lock ring	Bague de serrage goujon	Bolzenfeststellring	Anillo sujeta pasador
6	1616710 000	1		Gabbia	Cage	Cage	Lagerkäfig	Jaula
7	026020048 000	1		Biella completa	Conn.-rod, assy	Bielle compl.	Pleuel, kompl.	Biella compl.
8	1325010 000	1		Dado M12x1	Nut M12x1	Ecrou M12x1	Mutter M12x1	Tuerca M12x1
9	2774810 000	1		Rondella elastica	Spring Washer	Rondelle élastique	Federring	Arandela elástica
10	1064661 000	1		Anello paraolio	Oil seal	Joint d' é tanché ité	Ölschutzring	Retén de aceite
11	1299563 000	2		Cuscinetto 30x62x16 (6206)	Bearing 30x62x16 (6206)	Roulement 30x62x16 (6206)	Lager 30x62x16 (6206)	Cojinete 30x62x16 (6206)
12	026020090 000	1		Distanziale	Spacer	Entretoise	Distanzstück	Distanciator
13	C02010010 000	1		Anello paraolio 38.52.7	Oil seal 38.52.7	Joint d' é tanché ité 38.52.7	Ölschutzring 38.52.7	Retén de aceite 38.52.7
14	026030010 000	1		Pignone trasmissione primaria	Main Drive Sprocket	Pignon Transmission Primaire	Primä raantriebsritzel	Piñón Transmisión Primaria
15	006030230 000	1		Dado M20X1x5 LH	Nut M20X1x5 LH	Ecrou M20X1x5 LH	Mutter M20X1x5 LH	Tuerca M20X1x5 LH
16	1246020 000	1		Chiavetta 3x5	Key 3x5	Clavette 3x5	Keil 3x5	Chaveta 3x5
17	1246151 000	1		Linguetta 4x5 uni 6606	Plate 4x5 uni 6606	Plaquette 4x5 uni 6606	Plättchen 4x5 uni 6606	Lengüeta 4x5 uni 6606
18	1066620 000	1		Anello or 25,12x1,78	O-Ring 25,12x1,78	Bague d' é tanché ité 25,12x1,78	O-Ring 25,12x1,78	Anillo OR 25,12x1,78

Tav.03

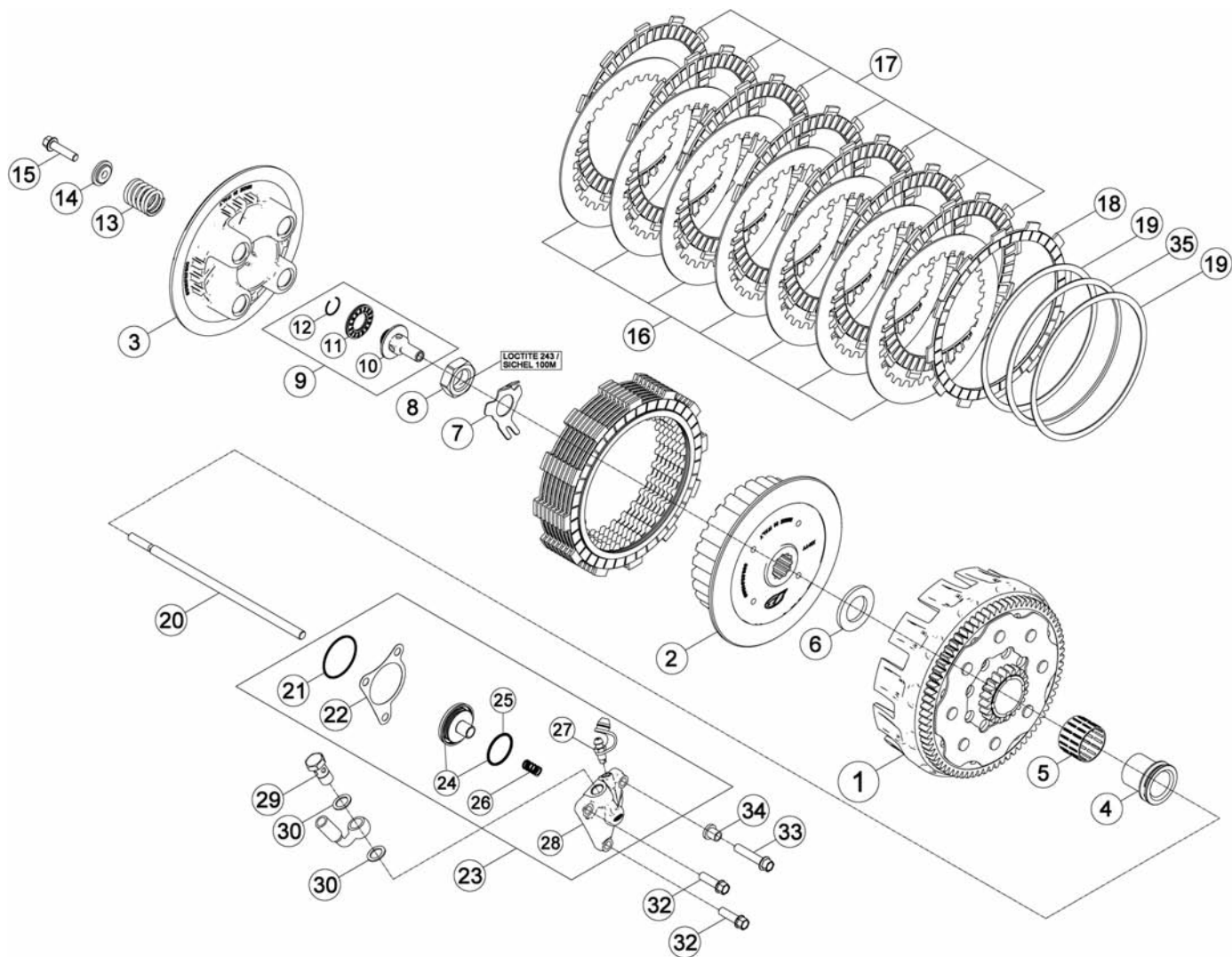

Tav.03

Pos Loc Pos Ps Pos	Numero Number Numéro Número Nummer	Q.tà Q.ty Q.té M.ge C.ad	Nota Note Note Nota Anm.	Descrizione	Description	Dé signation	Beschreibung	Descrìpziò n
1	026030118 000	1		Campana frizione compl.	Clutch case assembly	Cloche d' embrayage compl.	Kupplungsglocke.	Campana de embr.completa
2	006031400 000	1		Tamburo frizione	Clutch drum	Tambour d' embr.	Kupplungsstrommel	Tambor de embr.
3	006030300 000	1		Piatello spingidisco	Spring collar	Godet d' embrayage	Druckteller	Platillo embrague
4	026030610 000	1		Boccola	Bush	Moyeu	Büchse	Buje
5	006030630 000	1		Boccola a rulli 26x30.22	Roller bearing 26x30.22	Douille à roulements 26x30.22	Rollenbuchse 26x30.22	Caja de grasa de rodillos 26x30.22
6	006030620 000	1		Rondella 21,7x38.3.	Washer 21,7x38.3.	Rondelle 21,7x38.3.	U.Scheibe 21,7x38.3.	Arandela 21,7x38.3.
7	006030640 000	1		Rondella di sicurezza	Tab washer	Rondelle de sûreté	Sicherungs-Unterlegscheibe	Arandela de seguridad
8	006030650 000	1		Dado M18x1,5 h9	Nut M18x1,5 h9	Ecrou M18x1,5 h9	Mutter M18x1,5 h9	Tuerca M18x1,5 h9
9	006030718 000	1		Innesto Asta Corpo Frizione comp.	Clutch Housing Rod Coupling, assy	Crabot Tige Corps Embrayage compl.	Stabeinkupplung	Acople Varilla Cuerpo Embrague comp.
10	006030710 000	1		Innesto Asta Corpo Frizione	Clutch Housing Rod Coupling	Crabot Tige Corps Embrayage	Stabeinkupplung	Acople Varilla Cuerpo Embrague
11	006030630 000	1		Boccola a rulli 26x30.22	Roller bearing 26x30.22	Douille à roulements 26x30.22	Kupplungskö rper	Acople Varilla Cuerpo Embrague
12	2823105 000	1		Seeger RB14 DIN 7993	Circlip RB14 DIN 7993	Circlip RB14 DIN 7993	Rollenbuchse 26x30.22	Caja de grasa de rodillos 26x30.22
13	022030550 000	4		Molla frizione	Clutch spring	Ressort embr.	Seeger RB14 DIN 7993	Seeger RB14 DIN 7993
14	006031560 000	4		Reggimolla Frizione	Spring Retainer	Porte-Ressort Embrayage	Kupplg.feder	Muelle embr.
15	1150010 000	4		Bullone M6x25	Bolt M6x25	Boulon M6x25	Federteller	Portamuelle Embrague
16	006030500 000	7		Disco acciaio	Steel plate	Disque lisse	Bolzen M6x25	Tornillo M6x25
17	006030520 000	7		Disco frizione	Clutch disk	Disque embr.	Stahlscheibe	Disco
18	006031530 000	1		Disco frizione	Clutch disk	Disque embr.	Kupplungs-scheib	Disco de embrague
19	006030570 000	2		Rondella	Washer	Rondelle	Kupplungs-scheib	Disco de embrague
20	026030700 000	1		Astina frizione	Clutch fl. dipstick	Axe embrayage	U.Scheibe	Arandela
21	1066840 000	1		Anello OR 33x1,5	O-Ring 33x1,5	Bague d' é tanché ité 33x1,5	Kupplungsstange	Varita embrague
22	006030850 000	1		Guarnizione frizione	Clutch lining	Garniture embrayage	O-Ring 33x1,5	Anillo OR 33x1,5
23	006030808 000	1		Corpo attuatore	Actuator body	Corps actionneur	Kupplungsbelag	Forro de embrague
24	006030818 000	1		Pistone	Piston	Piston	Gehä use Stellantrieb	Cuerpo del actuador
25	1066520 000	1		Anello OR 23,52X1,78	O-Ring 23,52X1,78	Bague d' é tanché ité 23,52X1,78	Kolben	Pistó n
26	006030830 000	1		Molla	Spring	Ressort	O-Ring 23,52X1,78	Anillo OR 23,52X1,78
27	2891050 000	1		Tappo sfiato	Breather plug	Bouchon reniflard	Feder	Muelle
28	006030800 000	1		Corpo attuatore	Actuator body	Corps actionneur	Verschlu ß Entlü fter	Tapó n respiradero
29	1165040 000	1		Bullone forato 10x1 x tubo freno	Special bolt	Boulon 10x1 x tube frein	Gehä use Stellantrieb	Cuerpo del actuador
30	1650510 000	2		Guarnizione 10x15x1 in rame	Gasket 10x15x1 copper	Joint 10x15x1 cuivre	Hohlschraube F.Bremse	Tornillo esp. talad.10.1
32	1149070 000	2		Bullone 6x20 ch rs	Bolt 6x20 ch rs	Boulon 6x20 ch rs	Dichtung 10x15x1 Kupfer	Junta 10.15.1 (cobre)
33	1150300 000	1		Bullone 6x30 ch rs	Bolt 6x30 ch rs	Boulon 6x30 ch rs	Bolzen 6x20 ch rs	Tornillo 6x20 ch rs
34	1349190 000	1		Distanziale 10mm	Spacer 10mm	Entretoise 10mm	Bolzen 6x30 ch rs	Tornillo 6x30 ch rs
35	006031580 000	1		Molla a tazza	Belleville spring	Ressort à godet	Distanzstü ck 10mm	Distanciadór 10mm
							Tassenfeder	Muelle de taza

Tav.04A

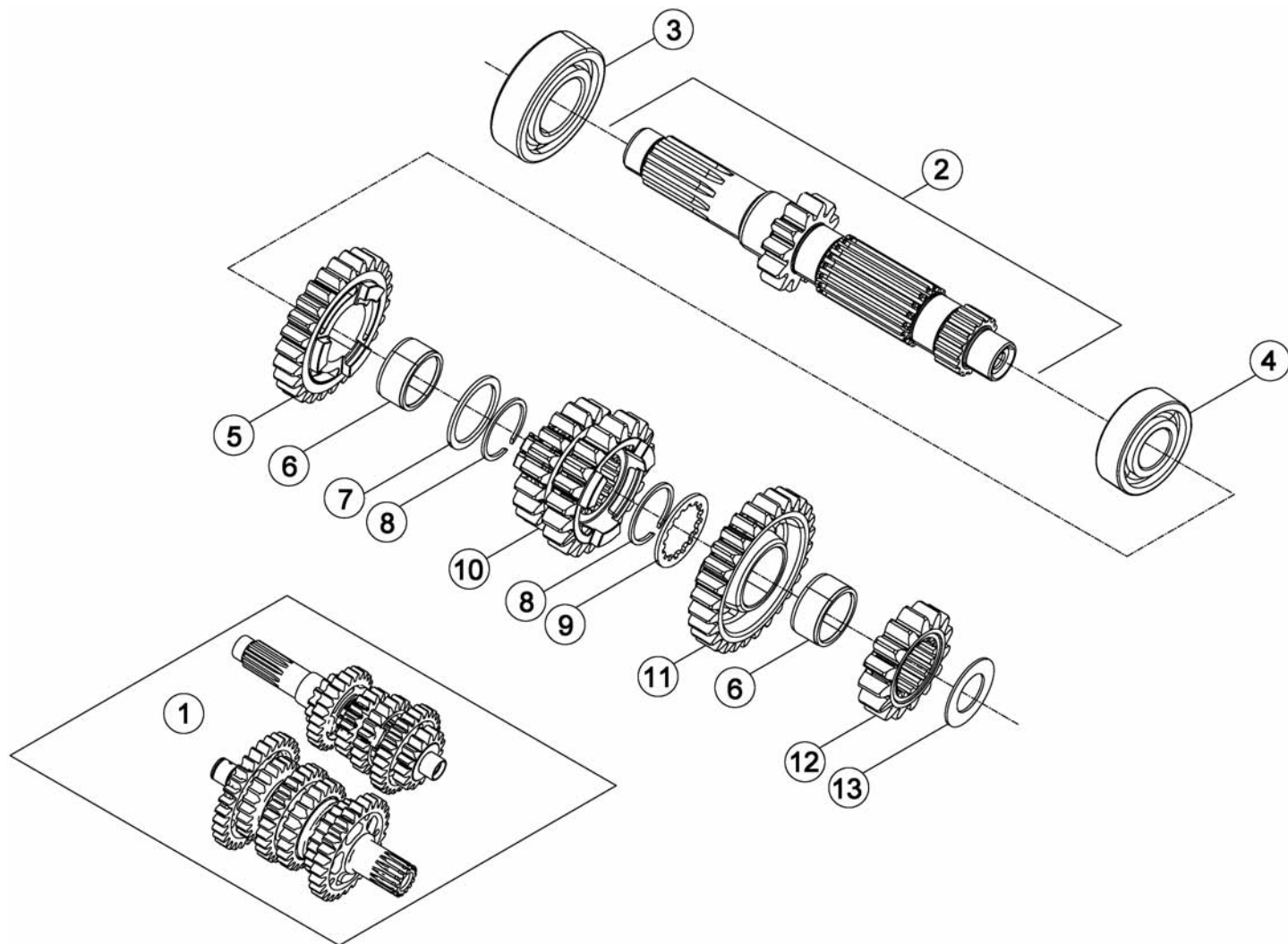

Pos Loc Pos Ps Pos	Numero Number Numéro Número Nummer	Q.tà Q.ty Q.té M.ge C.ad	Nota Note Note Nota Anm.	Descrizione	Description	Désignation	Beschreibung	Descripció
1	026040008 000	1		Cambio completo	Transmission, assy	Boî te de vitesses	Getriebe komplett	Cambio completo
2	026040100 000	1		Albero primario completo	Complete main shaft	Arbre primaire complet	Komplette Hauptwelle	Arbol primario completo
3	1295610 000	1		Cuscinetto 6205	Bearing 6205	Roulement 6205	Lager 6205	Cojinete 6205
4	1295605 000	1		Cuscinetto 6203	Bearing 6203	Roulement 6203	Lager 6203	Cojinete 6203
5	006040150 000	1		Quinta sul primario	Fifth gear - mainshaft	Cinquième sur le primaire	5. Gang auf antriebswelle	Quinta marcha en el cigüeñal primario
6	1122855 000	2		Gabbia a rulli 22x26x13	Roller cage 22x26x13	Cage a roul. 22x26x13	Rollenkäfig 22x26x13	Jaula de rod. 22x26x13
7	006040310 000	1		Rondella rasamento	Thrust washer	Rondelle de butée	Anlaufscheibe	Arandela distanciadora
8	2825460 000	1		Seeger 20SW	Circlip 20SW	Circlip 20SW	Seeger 20SW	Seeger 20SW
9	006040300 000	1		Rondella rasamento	Thrust washer	Rondelle de butée	Anlaufscheibe	Arandela distanciadora
10	006040130 000	1		Terza e quarta sul primario	Third and fourth gear - mainshaft	Troisième et quatrième sur le primaire	3. Gang und 4. Gang auf antriebswelle	Tercera y Cuarta marcha en el cigüeñal primario
11	006040160 000	1		Sesta sul primario	6th gear - mainshaft	Sixième sur le primaire	6. Gang auf antriebswelle	Sexta marcha en el cigüeñal primario
12	006040120 000	1		Seconda sul primario	Second gear - mainshaft	Deuxième sur le primaire	2. Gang auf abtriebswelle	Segunda marcha en el cigüeñal primario
13	006040320 000 006040520 000	1 1		Rondella rasamento 17x30x1 Pignone	Thrust washer 17x30x1 Pinion	Rondelle de butée 17x30x1 Pignon	Anlaufscheibe 17x30x1 Ritzel	Arandela distanciadora 17x30x1 Piñón



Beta
the play bike

Tav.04B

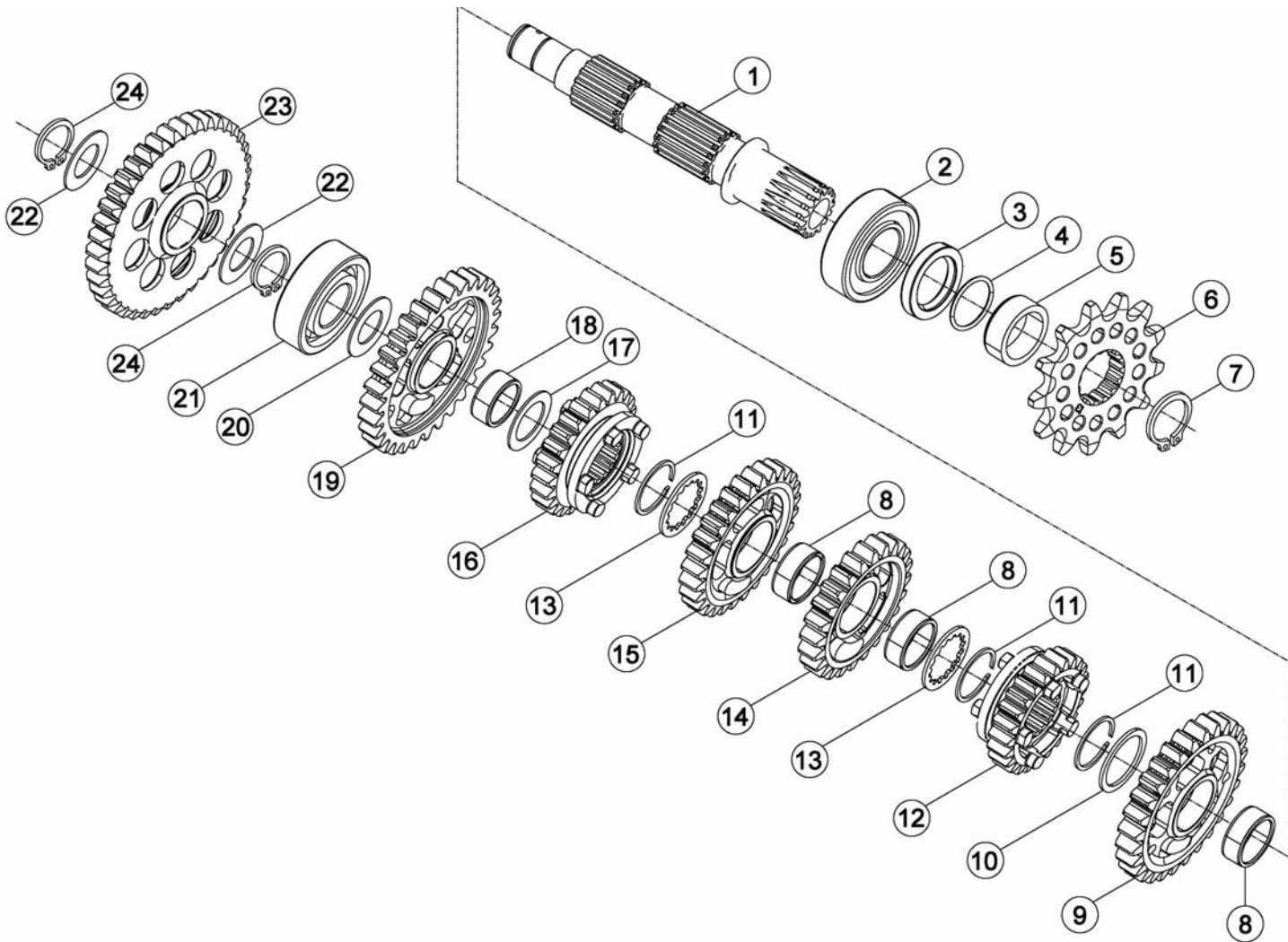

Pos Loc Pos Ps Pos	Numero Number Numéro Número Nummer	Q.tà Q.ty Q.té M.ge C.ad	Nota Note Note Nota Anm.	Descrizione	Description	Désignation	Beschreibung	Descripció
1	026040200 000	1		Albero secondario	Counter shaft	Arbre secondaire	Nebengeriebewelle	Eje secundario
2	1299710 000	1		Cuscinetto NJ205	Bearing NJ205	Roulement NJ205	Lager NJ205	Cojnete NJ205
3	1066020 000	1		Anello paraolio 32x45x6x5	Oil seal 32x45x6x5	Joint d' é tanché ité 32x45x6x5	Ölschutzring 32x45x6x5	Reté n de aceite 32x45x6x5
4	1066540 000	1		Anello OR 24.2	O-Ring 24.2	Bague d' é tanché ité 24.2	O-Ring 24.2	Anillo OR 24.2
5	006040400 000	1		Distanziale	Spacer	Entretoise	Distanzstück	Distanciador
6	006040500 000	1		Pignone Z=13	Pinion Z=13	Pignon Z=13	Ritzel Z=13	Piñ ó n Z=13
6	006040520 000	1		Pignone Z=15 omologazione	Pinion Z=15 homologation	Pignon Z=15 homologation	Ritzel Z=15 Zulassung	Piñ ó n Z=15 homologació n
7	2825530 000	1		Anello seeger 25x2	Snap ring 25x2	Circlips 25x2	Seegerring 25x2	Anillo seeger 25x2
8	1122845 000	3		Gabbia a rulli 22x26x10	Roller cage 22x26x10	Cage a roul. 22x26x10	Rollenkä fig 22x26x10	Jaula de rod. 22x26x10
9	006040220 000	1		Seconda sul secondario	Second gear - layshaft	Deuxiè me sur le secondaire	2. Gang auf Vorgelegewelle	Segunda marcha en el cigü eñ al sec.
10	006040310 000	1		Rondella rasamento	Thrust washer	Rondelle de buté e	Anlaufscheibe	Arandela distanciadora
11	2825460 000	3		Seeger 20SW	Circlip 20SW	Circlip 20SW	Seeger 20SW	Seeger 20SW
12	006040260 000	1		Sesta sul secondario	6th gear - layshaft	Sixiè me sur le secondaire	6. Gang auf Vorgelegewelle	Sextsa marcha en el cigü eñ al sec.
13	006040300 000	2		Rondella rasamento	Thrust washer	Rondelle de buté e	Anlaufscheibe	Arandela distanciadora
14	006040240 000	1		Quarta sul secondario	Fourth gear - layshaft	Quatriè me sur le secondaire	4. Gang auf Vorgelegewelle	Cuarta marcha en el cigü eñ al sec.
15	006040230 000	1		Terza sul secondario	Third gear - layshaft	Troisiè me sur le secondaire	3. Gang auf Vorgelegewelle	Tercera marcha en el cigü eñ al sec.
16	006040250 000	1		Quinta sul secondario	Fifth gear - layshaft	Cinquiè me sur le secondaire	5. Gang auf Vorgelegewelle	Quinta marcha en el cigü eñ al sec.
17	006040330 000	1		Rondella rasamento 20x30x1	Thrust washer 20x30x1	Rondelle de buté e 20x30x1	Anlaufscheibe 20x30x1	Arandela distanciadora 20x30x1
18	1122835 000	1		Gabbia a rulli 20x24x10	Roller cage 20x24x10	Cage a roul. 20x24x10	Rollenkä fig 20x24x10	Jaula de rod. 20x24x10
19	006040210 000	1		Prima sul secondario	First gear - layshaft	Premiè re sur le secondaire	1. Gang auf Vorgelegewelle	Primera marcha en el cigü eñ al secundario
20	006040320 000	1		Rondella rasamento 17x30x1	Thrust washer 17x30x1	Rondelle de buté e 17x30x1	Anlaufscheibe 17x30x1	Arandela distanciadora 17x30x1
21	1295605 000	1		Cuscinetto 6203	Bearing 6203	Roulement 6203	Lager 6203	Cojnete 6203
22	2772560 000	2		Rondella spessoramento 18x27	Spacer washer 18x27	Entretoise 18x27	Distanzscheibe 18x27	Arandela distanciadora 18x27
23	026060318 000	1		Ingranaggio rinvio m.m.	Kickstart idler gear	Pignon de renvoi de dé marr.	Zwischenrad starter	Engr. de reenvio arranque
24	2824955 000	2		Seeger 17x1,5	Circlip 17x1,5	Circlip 17x1,5	Seeger 17x1,5	Seeger 17x1,5

Tav.05

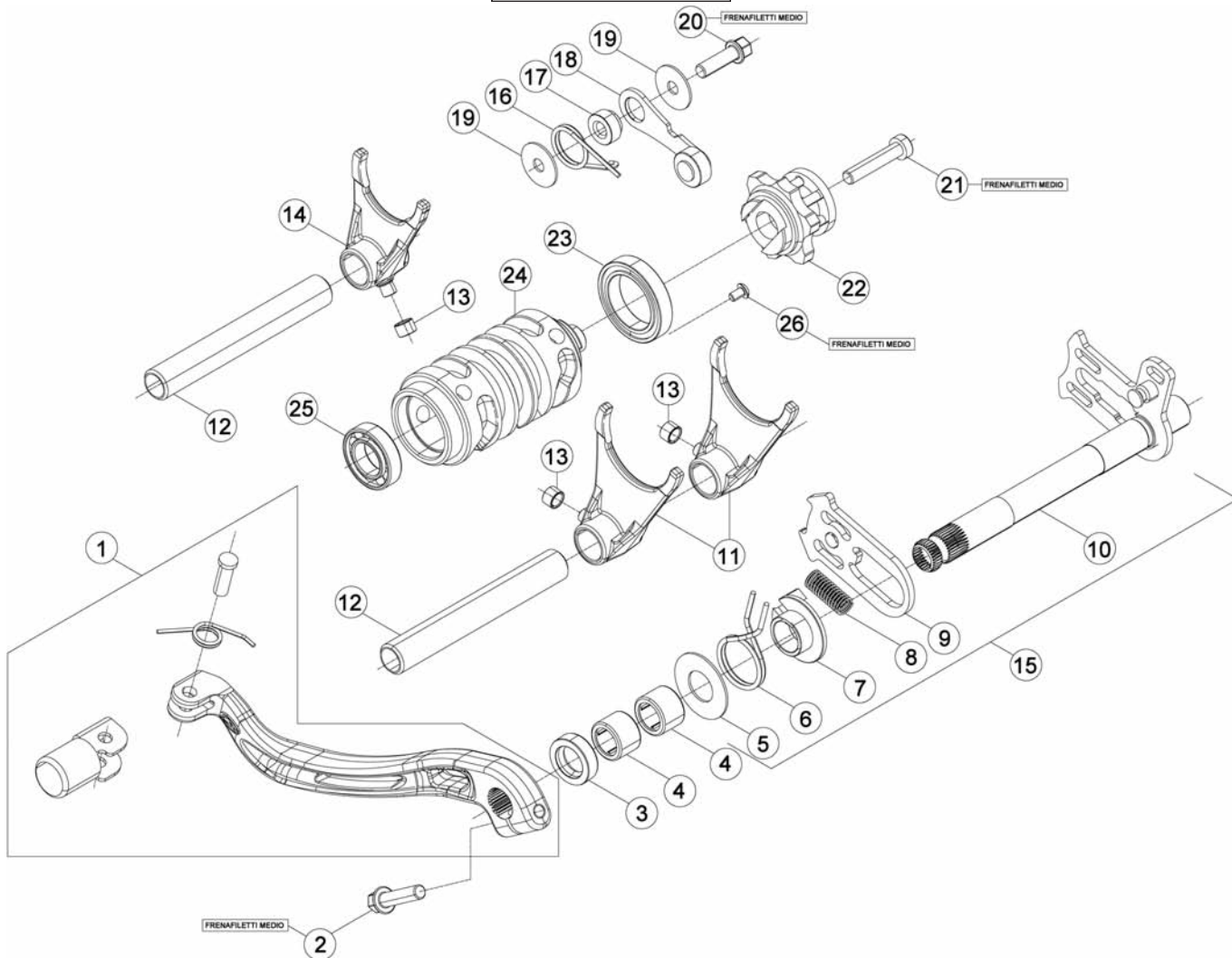

Pos Loc Pos Ps Pos	Numero Number Numéro Número Nummer	Q.tà Q.ty Q.té M.ge C.ad	Nota Note Note Nota Anm.	Descrizione	Description	Désignation	Beschreibung	Descripción
1	006050008 000	1		Leva cambio	Gear change lever	Levier comm. chang. vit.	Schalthebel	Palanca cambio
1	006050008 059	1	RACING	Leva cambio	Gear change lever	Levier comm. chang. vit.	Schalthebel	Palanca cambio
2	1150010 000	1		Bullone M6x25	Bolt M6x25	Boulon M6x25	Bolzen M6x25	Tornillo M6x25
3	1052012 000	1		Anello paraolio 14x24.6	Oil seal 14x24.6	Joint d' é tanché ité 14x24.6	Ölschutzring 14x24.6	Retén de aceite 14x24.6
4	1122320 000	2		Boccola a rulli	Roller bearing	Douille à roulements	Rollenbuchse	Caja de grasa de rodillos
5	2763020 000	1		Rondella rasamento 14x30x1	Thrust washer 14x30x1	Rondelle de buté e 14x30x1	Anlaufscheibe 14x30x1	Arandela distanciadora 14x30x1
6	006050170 000	1		Molla ritorno comando cambio	Gearchange return spring	R ressort de retour comm. ch.ge vit.	Rückstellfeder schaltung	Muelle de retorno cambio
7	1692911 000	1		Guida molla	Spring guide	Guide ressort	Federfuehrung	Guia de resorte
8	006050160 000	1		Molla 0,8MM	Spring 0,8MM	R ressort 0,8MM	Feder 0,8MM	Muelle 0,8MM
9	006050148 000	1		Ventaglio mobile	Movable pawl	Eventail mobile	Schaltautomat	Abanico mó vil
10	026050118 000	1		Albero comando cambio	Gearshift shaft	Arbre de vitesse	Schaltwelle	Eje mando cambio
11	006050200 000	2		Forchetta 1/4	Fork 1/4	Fourchette 1/4	Schaltgabel 1/4	Horquilla 1/4
12	026050250 000	2		Perno forchetta	Spindle, fork	Axe de fourche	Schaltgabelstift	Perno de la horquilla
13	006050270 000	3		Boccola 6x8.5.2.	Bush 6x8.5.2.	Moyeu 6x8.5.2.	Bü chse 6x8.5.2.	Buje 6x8.5.2.
14	006050210 000	1		Forchetta 5/6	Fork 5/6	Fourchette 5/6	Schaltgabel 5/6	Horquilla 5/6
15	026050108 000	1		Albero cambio compl.	Gear shaft assy.	Arbre Boi te à vitesse compl.	Getriebewelle kpl.	Eje cambio compl.
16	2239590 000	1		Molla arresto marce	Gear stop spring	R ressort arrê t vit.	Gangstopfeder	Muelle arresto vel.
17	006050540 000	1		Distanziale	Spacer	Entretoise	Distanzstü ck	Distanciador
18	026050508 000	1		Leva arresto marce	Gear stop lever	Levier arrê t vit.	Gangstopphebel	Palanca arresto vel.
19	2742000 100	2		Rondella 6x20.1,0	Washer 6x20.1,0	Rondelle 6x20.1,0	U.Scheibe 6x20.1,0	Arandela 6x20.1,0
20	1149070 000	1		Bullone 6x20 ch rs	Bolt 6x20 ch rs	Boulon 6x20 ch rs	Bolzen 6x20 ch rs	Tornillo 6x20 ch rs
21	3145000 000	1		Vite TCCE 6.30	Screw TCCE 6.30	Vis TCCE 6.30	Schraube TCCE 6.30	Tornillo TCCE 6.30
22	006050408 000	1		Camma Arresto Marce	Gear Stopper Cam	Came Buté e Vitesses	Gangsperrnocken	Leva Parada Marchas
23	1293405 000	1		Cuscinetto 61805	Bearing 61805	Roulement 61805	Lager 61805	Cojinete 61805
24	026050300 000	1		Camma cambio	Selector drum	Barillet de sé lection de boi te de vit.	Schaltwalze	Leva de la caja de cambios
25	1293840 000	1		Cuscinetto 15x28x7	Bearing 15x28x7	Roulement 15x28x7	Lager 15x28x7	Cojinete 15x28x7
26	3130084 000	1		Vite M5X8	Screw M5X8	Vis M5X8	Schraube M5X8	Tornillo M5X8



Beta
the play bike

Tav.06

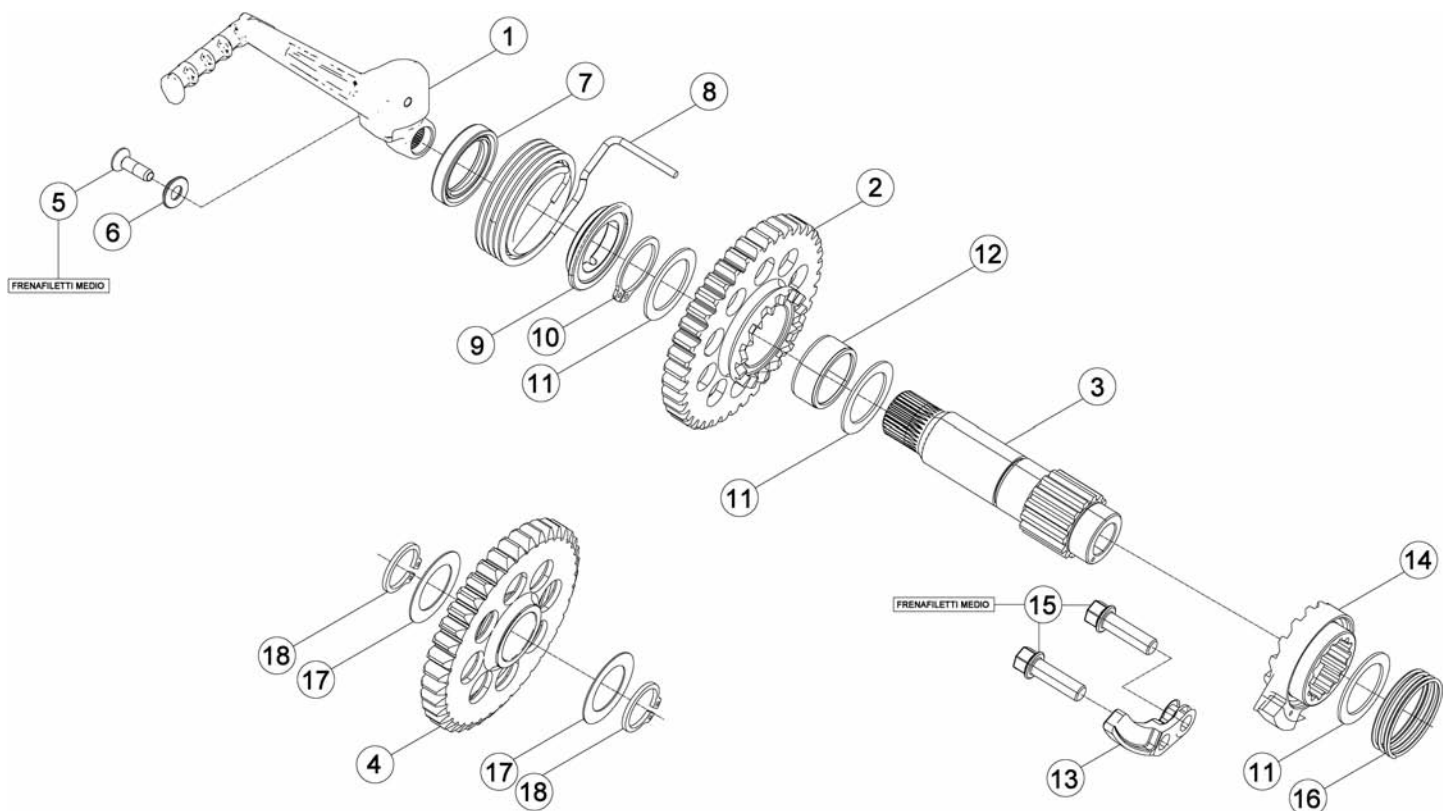

Pos Loc Pos Ps Pos	Numero Number Numéro Número Nummer	Q.tà Q.ty Q.té M.ge C.ad	Nota Note Note Nota Anm.	Descrizione	Description	Désignation	Beschreibung	Descripcìon
1	006060008 000	1		Leva messa in moto	Start. lever	Lev. du dé m.	Kickstarterhebel	Palanca de arranque
2	006060110 000	1		Ingranaggio messa in moto	Kickstart gear	Pignon de dé marriage	Startergetriebe	Engranaje del arranque
3	006060100 000	1		Albero messa in moto	Kickstarter shaft	Arbre du dé marreur	Starterwelle	Eje puesta en marcha
4	026060318 000	1		Ingranaggio rinvio m.m.	Kickstart idler gear	Pignon de renvoi de dé marr.	Zwischenrad starter	Engr. de reenvio arranque
5	3196827 000	1		Vite speciale M8X26	Special screw M8X26	Vis spéciale M8X26	Spezialschraube M8X26	Tornillo especial M8X26
6	006060080 000	1		Rondella	Washer	Rondelle	U.Scheibe	Arandela
7	1064490 000	1		Anello paraolio 20x30.5/6	Oil seal 20x30.5/6	Joint d' é tanché ité 20x30.5/6	Ölschutzring 20x30.5/6	Reté n de aceite 20x30.5/6
8	006060130 000	1		Molla richiamo albero messa in moto	Return spring kickstarter shaft	Ressort de rappel arbre du dé marreur	Rückzugsfeder Starterwelle	Muelle de retorno eje puesta en marcha
9	006061120 000	1		Distanziale messa in moto	Spacer, kickstart	Entretroise dé marriage	Distanzstück starter	Distanciadador del arranque
10	2825400 000	1		Seeger 20e	Circlip 20e	Circlip 20e	Seeger 20e	Seeger 20e
11	2773600 100	3		Rondella spessoramento 20x28.1	Spacer washer 20x28.1	Entretroise 20x28.1	Distanzscheibe 20x28.1	Arandela distanciadora 20x28.1
12	1122835 000	1		Gabbia a rulli 20x24x10	Roller cage 20x24x10	Cage a roul. 20x24x10	Rollenkäfig 20x24x10	Jaula de rod. 20x24x10
13	006060160 000	1		Rampa messa in moto	Kickstart ramp	Rampe de dé marriage	Starterrampe	Rampa para el arranque
14	006060140 000	1		Manicotto messa in moto	Kickstart sleeve	Manchon de dé marriage	Muffe starter	Manguito arranque
15	1149070 000	2		Bullone 6x20 ch rs	Bolt 6x20 ch rs	Boulon 6x20 ch rs	Boizen 6x20 ch rs	Tornillo 6x20 ch rs
16	006060150 000	1		Molla	Spring	Ressort	Feder	Muelle
17	2771220 000	2		Rondella spess. 17.25	Washer 15x25 17.25	Rondelle epaisseur 15x25 17.25	Scheibe 15x25 17.25	Arandela 15x25 17.25
18	C01230010 000	2		Anello di fermo 17x1	Check ring 17x1	Bague d' arrêt 17x1	Sicherungsring 17x1	Anillo de bloqueo 17x1

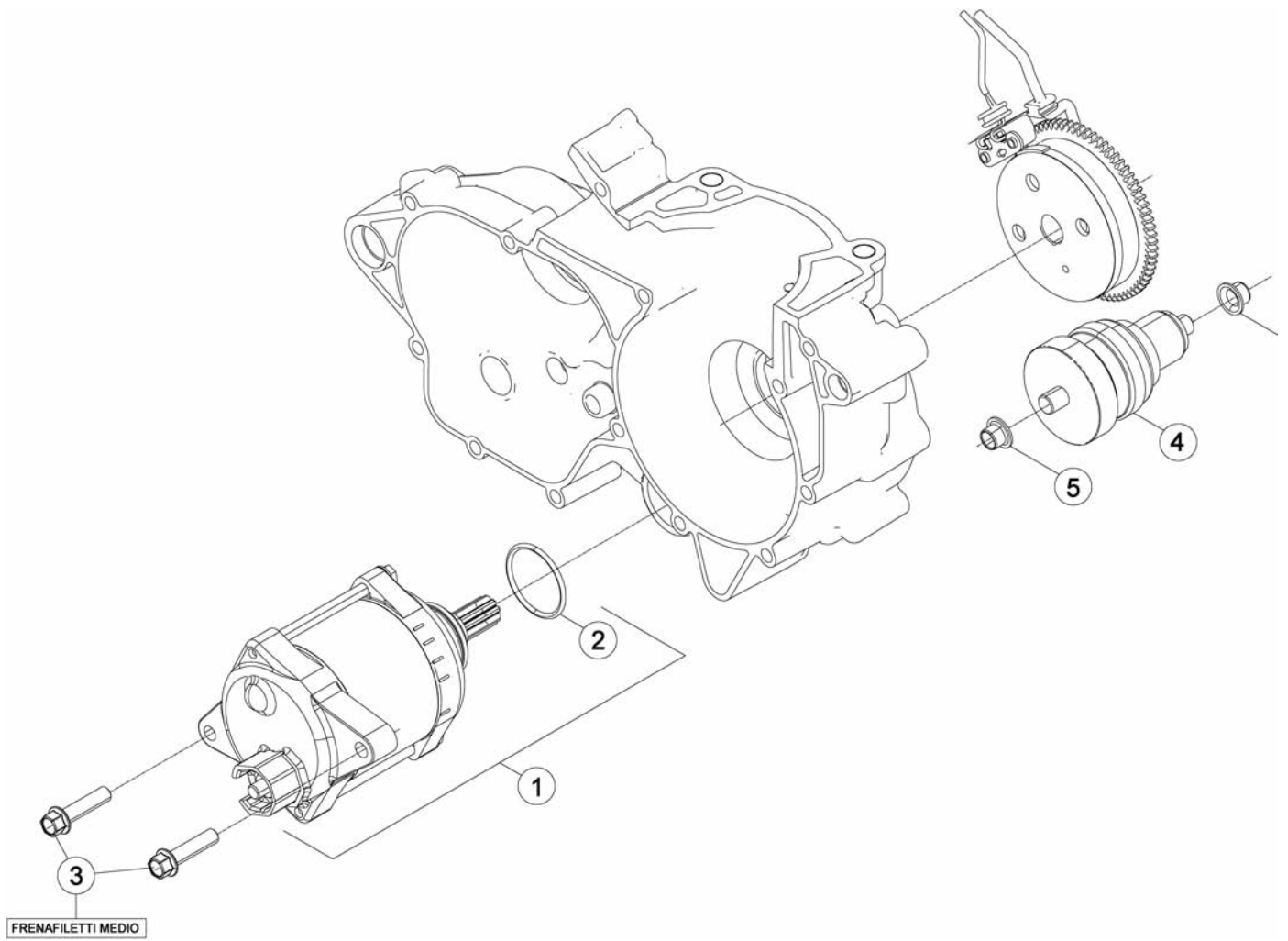

Tav.07

Pos Loc Pos Ps Pos	Numero Number Numéro Número Nummer	Q.tà Q.ty Q.té M.ge C.ad	Nota Note Nota Nota Anm.	Descrizione	Description	Dé signation	Beschreibung	Descrìciò n
1	026070008 000	1		Motorino avviamento	Starter motor	Moteur du dé marreur	Startermotor	Motor de arranque
2	3625056 000	1		Anello OR 25,00x3,00	O-Ring 25,00x3,00	Bague d' é tanché ité 25,00x3,00	O-Ring 25,00x3,00	Anillo OR 25,00x3,00
3	1150010 000	2		Bullone M6x25	Bolt M6x25	Boulon M6x25	Bolzen M6x25	Tornillo M6x25
4	026070100 000	1		Innesto	Contact tag	Cosse	Stecker	Toma de contacto
5	C03020010 000	2		Boccola 8x10x8	Bush 8x10x8	Moyeu 8x10x8	Büchse 8x10x8	Buje 8x10x8

Tav.09

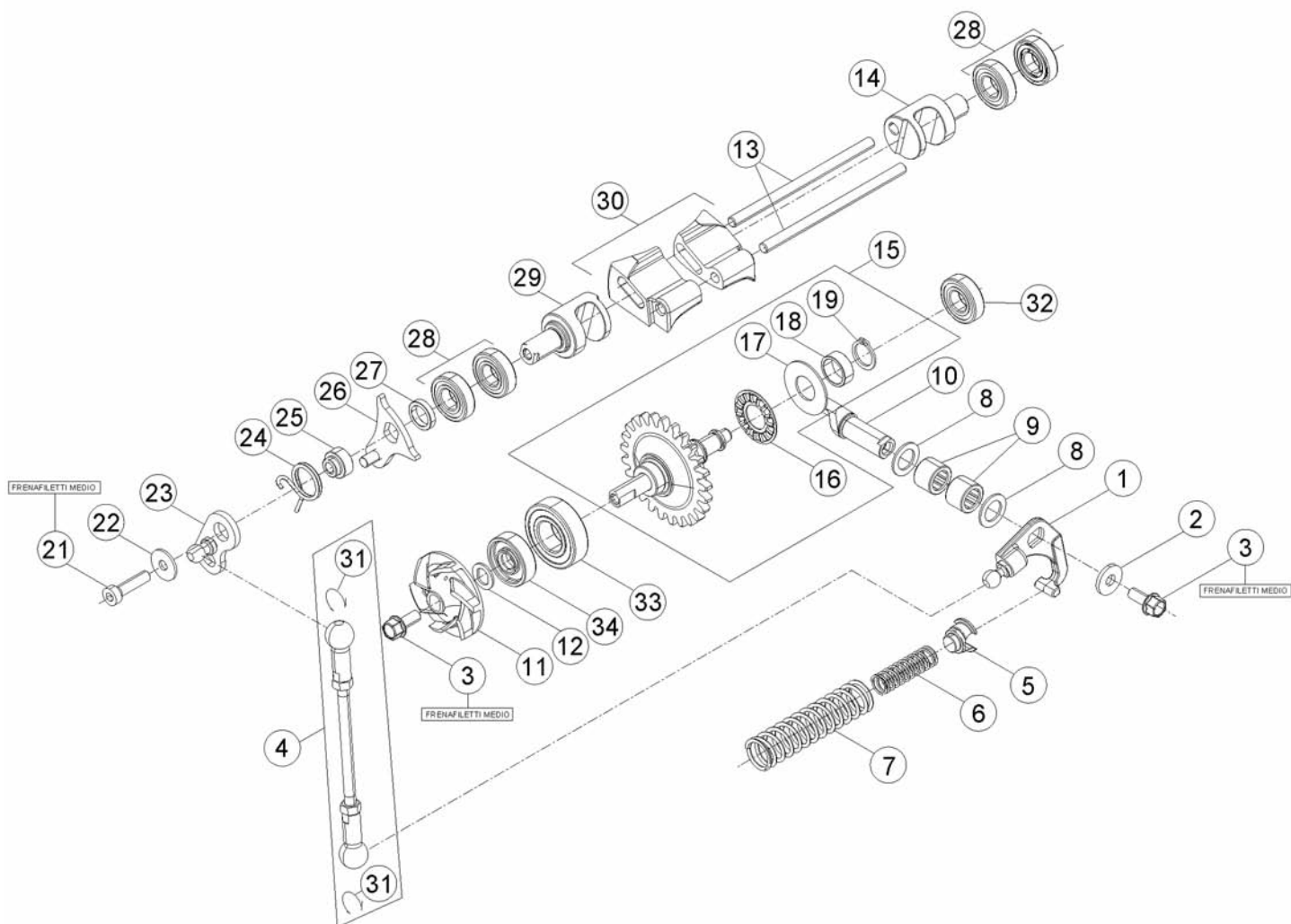

Tav.09

Pos Loc Ps Pos	Numero Number Numéro Nummer	Q.tà Q.ty Q.té M.ge C.ad	Nota Note Nota Anm.	Descrizione	Description	Dé signation	Beschreibung	Descrìpziò n
1	026090138 000	1		Bilanciere compl.	Rocker arm assy	Culbuteur compl.	Kipphebel kpl.	Balanci n compl.
2	C16020010 000	1		Rondella 5.15.2	Washer 5.15.2	Rondelle 5.15.2	U.Scheibe 5.15.2	Arandela 5.15.2
3	1146251 000	2		Bullone flangiato M5x12	Head Flanged bolt M5x12	Boulon Bridé M5x12	Bundbolzen M5x12	Bulón con Brida M5x12
4	026090158 000	1		Asta comando valvola	Valve control rod	Tige de commande soupape	Ventilsteuerungsstab	Varilla mando válvula
5	026090170 000	1		Guida molla	Spring guide	Guide ressort	Federfuehrung	Guia de resorte
6	026090180 000	1		Molla	Spring	Ressort	Feder	Muelle
7	026090210 000	1	250cc	Molla regolazione 250cc	Adjusting spring 250cc	Ressort de réglage 250cc	Feder, Einstell 250cc	Muelle de regul. 250cc
7	026090190 000	1	300cc	Molla regolazione 300cc	Adjusting spring 300cc	Ressort de réglage 300cc	Feder, Einstell 300cc	Muelle de regul. 300cc
8	2758400 000	2		Rondella 10.16.1	Washer 10.16.1	Rondelle 10.16.1	U.Scheibe 10.16.1	Arandela 10.16.1
9	1122100 000	2		Boccola a rulli 10x14x10	Roller bearing 10x14x10	Douille à roulements 10x14x10	Rollenbuchse 10x14x10	Caja de grasa de rodillos 10x14x10
10	026090110 000	1		Leva controllo	Control Lever	Lever De Commande	Steuerhebel	Palanca Control
11	006090000 000	1		Girante pompa	Rotor	Roue de pompe	Wasserpumpenrad	Rotor de la bomba
12	006090120 000	1		Rondella	Washer	Rondelle	U.Scheibe	Arandela
13	026090310 000	2		Perno valvola di scarico	Exhaust valve pin	Pivot soupape d' é chapp.	Stift Auslassventil	Perno válvula de descarga
14	026090400 000	1		Valvola BOOSTER	BOOSTER valve	Soupape BOOSTER	Auslass BOOSTER	Vá lvula BOOSTER
15	026090008 000	1		Unità centrifuga	Centrifugal unit	Unité centrifuge	Zentrifugaleinheit	Unidad centrí fuga
16	1611512 000	1		Gabbia assiale a rullini	Axial needle collar	Cage à aiguilles axiale	Axial-Nadelkranz	Jaula de agujas del cojinete
17	2756400 000	1		Ralla	Washer	Rondelle	Scheibe	Arandela
18	026090030 000	1		Distanziale	Spacer	Entretoise	Distanzstück	Distanciadór
19	2822760 000	1		Seeger A12	Circlip A12	Circlip A12	Seeger A12	Seeger A12
21	3130015 000	1		Vite a brugola 5x20	Allen screw 5x20	Vis à 6 pans 5x20	Sechskantschraube 5x20	Tornillo a llave allen 5x20
22	2736500 000	1		Rondella Ø5	Washer Ø5	Rondelle Ø5	U.Scheibe Ø5	Arandela Ø5
23	026090428 500	1		Leva comando	Operating lever	Lever commande	Betaetigungshebel	Palanca de mando
24	026090460 000	1		Molla	Spring	Ressort	Feder	Muelle
25	026090440 000	1		Distanziale	Spacer	Entretoise	Distanzstück	Distanciadór
26	026090438 500	1		Leva fine corsa	Travel limit lever	Lever fin de course	Endanschlaghebel	Palanca final de carrera
27	026090470 000	1		Distanziale	Spacer	Entretoise	Distanzstück	Distanciadór
28	1293410 000	4		Cuscinetto	Bearing	Roulement	Lager	Cojinete
29	026090410 000	1		Valvola BOOSTER	BOOSTER valve	Soupape BOOSTER	Auslass BOOSTER	Vá lvula BOOSTER
30	026091320 000	1	250cc	Valvola di scarico 250cc	Exhaust valve 250cc	Soupape d' é chapp. 250cc	Auslassventil 250cc	Vá lvula de descarga 250cc
30	026090320 000	1	300cc	Valvola di scarico 300cc	Exhaust valve 300cc	Soupape d' é chapp. 300cc	Auslassventil 300cc	Vá lvula de descarga 300cc
31	C21310010 000	2		Molla sicurezza	Locking spring	Ressort surete	Sicherungsfeder	Resorte de seguridad
32	1293387 000	1		Cuscinetto 6.19.6	Bearing 6.19.6	Roulement 6.19.6	Lager 6.19.6	Cojinete 6.19.6
33	C06010010 000	1		Cuscinetto 15.32.9 6002-2RSH C3	Bearing 15.32.9 6002-2RSH C3	Roulement 15.32.9 6002-2RSH C3	Lager 15.32.9 6002-2RSH C3	Cojinete 15.32.9 6002-2RSH C3
34	1043720 000	1		Anello paraolio 8.24.7	Oil seal 8.24.7	Joint d' é tanché ité 8.24.7	Ölschutzring 8.24.7	Reté n de aceite 8.24.7

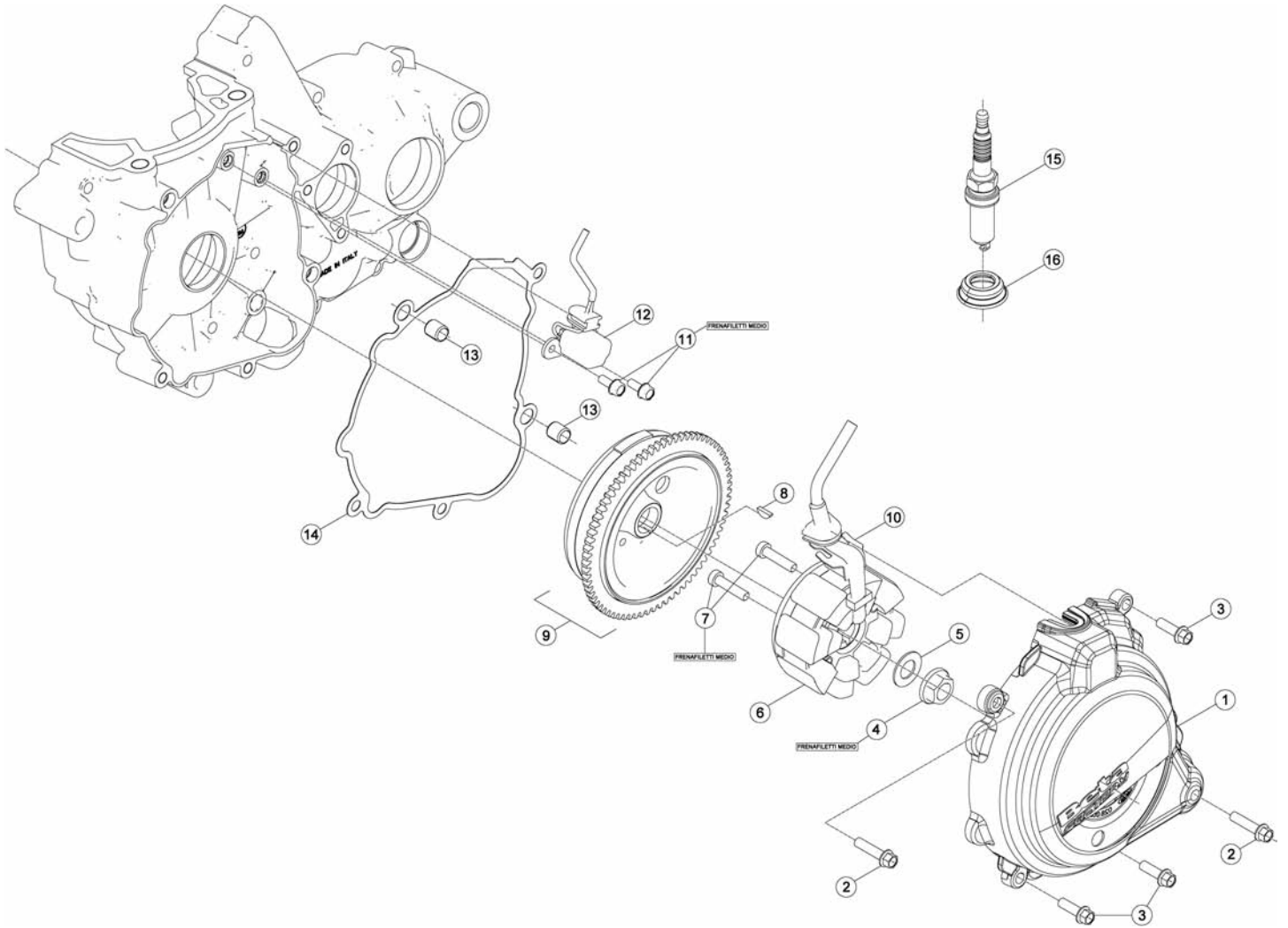

Tav.10

Pos Loc Ps Pos	Numero Number Numéro Número Nummer	Q.tà Q.ty Q.té M.ge C.ad	Nota Note Nota Anm.	Descrizione	Description	Dé signation	Beschreibung	Descrìpziò n
1	026010518 052	1		Coperchio volano	Flywheel cover	Carter volant	Schwungraddeckel	Tapa volante
2	1150010 000	2		Bullone M6x25	Bolt M6x25	Boulon M6x25	Bolzen M6x25	Tornillo M6x25
3	1149070 000	3		Bullone 6x20 ch rs	Bolt 6x20 ch rs	Boulon 6x20 ch rs	Bolzen 6x20 ch rs	Tornillo 6x20 ch rs
4	1325010 000	1		Dado M12x1	Nut M12x1	Ecrou M12x1	Mutter M12x1	Tuerca M12x1
5	2774810 000	1		Rondella elastica	Spring Washer	Rondelle é lastique	Federring	Arandela elástica
6	006100200 000	1		Statore	Backplate	Stator	Ankerplatte	Estatore
7	3148507 000	2		Vite tce testa ribassata M6x25	Screw tce, shallow head M6x25	Vis tce à tête basse M6x25	Schraube tce senkkopf M6x25	Tornillo tce de cabeza rebajada M6x25
8	1246020 000	1		Chiavetta 3x5	Key 3x5	Clavette 3x5	Keil 3x5	Chaveta 3x5
9	026100018 500	1		Rotore volano	Flywheel rotor	Rotor volant	Rotor schwungrad	Rotor volante
10	006010540 000	1		Piastrina	Plate	Plaque	Plättchen	Placa
11	1146251 000	2		Bullone flangiato M5x12	Head Flanged bolt M5x12	Boulon Bridé M5x12	Bundbolzen M5x12	Bulón con Brida M5x12
12	026100030 000	1		Pick up	Pick-up	Capteur	Pick-up	Pick-up
13	1636500 000	2		Grano 9x7,2x10	Dowel 9x7,2x10	Goujon 9x7,2x10	Stift 9x7,2x10	Clavija 9x7,2x10
14	026010530 000	1		Guarnizione coperchio volano	Alternator cover gasket	Garniture couvercle alternateur	Alternatordeckeldichtung	Junta tapa alternador
15	1225128 000	1		Candela	Spark.plug	Bougie	Zundkerze	Bujia
15	1225220 000	1		Candela	Spark.plug	Bougie	Zundkerze	Bujia
16	026100120 000	1		Guarnizione candela	Spark plug gasket	Joint bougie		Junta bujia

Tav.11

Pos Loc Ps Pos	Numero Number Numéro Nummer	Q.tà Q.ty Q.té M.ge C.ad	Nota Note Note Anm.	Descrizione	Description	Dé signation	Beschreibung	Descrìpziò n
1	1225128 000	1	250cc	Candela	Spark.plug	Bougie	Zündkerze	Bujia
1	1225220 000	1	300cc	Candela	Spark.plug	Bougie	Zündkerze	Bujia
2	026100120 000	1		Guarnizione candela	Spark plug gasket	Joint bougie	Zündkerzendichtring	Junta bujia
3	026110110 000	6		Vite flangiata M8x35	Flange bolt M8x35	Boulon de bride M8x35	Flanschschraube M8x35	Perno de borde M8x35
4	026110100 000	6		Rosetta 8.16.1	Washer 8.16.1	Rondelle 8.16.1	Federring 8.16.1	Arandela 8.16.1
5	026111068 052	1	250cc	Testa completa 250cc	Cylinder head 250cc	Culasse complete 250cc	Zylinderkopf Kpl. 250cc	Culata completa 250cc
5	026110068 052	1	300cc	Testa completa 300cc	Cylinder head 300cc	Culasse complete 300cc	Zylinderkopf Kpl. 300cc	Culata completa 300cc
5	026110148 052	1	300cc	Testa completa 300cc	Cylinder head 300cc	Culasse complete 300cc	Zylinderkopf Kpl. 300cc	Culata completa 300cc
RACING								
6	1066972 000	1	250cc	Anello OR 73.2	O-Ring 73.2	Bague d' é tanché ité 73.2	O-Ring 73.2	Anillo OR 73.2
6	1066973 000	1	300cc	Anello OR	O-Ring	Bague d' é tanché it	O-Ring	Anillo OR
7	1066978 000	1		Anello OR 105.2	O-Ring 105.2	Bague d' é tanché ité 105.2	O-Ring 105.2	Anillo OR 105.2
8	026110000 000	1	250cc	Cilindro 250cc	Cylinder 250cc	Cylindre 250cc	Zylinder 250cc	Cilindro 250cc
8	026110000 000	1	300cc	Cilindro 300cc	Cylinder 300cc	Cylindre 300cc	Zylinder 300cc	Cilindro 300cc
8	026110100 000	1	300cc	Cilindro 300cc	Cylinder 300cc	Cylindre 300cc	Zylinder 300cc	Cilindro 300cc
RACING								
9	1146360 000	7		Bullone flangiato M5x16	Head Flanged bolt M5x16	Boulon Bridé M5x16	Bundbolzen M5x16	Bulón con Brida M5x16
10	026110022 000	1		Coperchio valvola Dx.	Right valve head cover	Couvercle soupape D.	Ventilabdeckung rechts	Tapa vá lvula der.
11	026110030 000	1		Guarnizione coperchio valvola dx.	Right valve cover gasket	Garniture couvercle soupape D.	Ventildeckeldichtung rechts	Junta tapa vá lvula der.
12	026110040 052	1		Coperchio valvola Sx.	Left valve head cover	Couvercle soupape G.	Ventilabdeckung links	Tapa vá lvula izq.
13	026110050 000	1		Guarnizione coperchio valvola sx.	Left valve cover gasket	Garniture couvercle soupape G.	Ventildeckeldichtung links	Junta tapa vá lvula izq.
14	026110120 000	1		Tube sfciato	Breather tube	Tuyau ré niflard	Entlüftungsleitung	Tube respiradero
15	2740500 000	2		Rondella 6x13	Washer 6x13	Rondelle 6x13	U.Scheibe 6x13	Arandela 6x13
16	1320210 000	4		Dado speciale M10x1,25 ch 13	Special nut M10x1,25 ch 13	Ecrou spé ciale M10x1,25 ch 13	Spezialmutter M10x1,25 ch 13	Tuerca especial M10x1,25 ch 13
17	C24760010 000	2		Prigioniero M10x30x1,25	Stud M10x30x1,25	Goujon M10x30x1,25	Stiftschraube M10x30x1,25	Espá rrago M10x30x1,25
18	C24760020 000	2		Prigioniero M10x35x1,25	Stud M10x35x1,25	Goujon M10x35x1,25	Stiftschraube M10x35x1,25	Espá rrago M10x35x1,25
19	026110200 000	1		Guarnizione base cilindro SP. 0,3	Cylinder base gasket SP. 0,3	Garniture base cylindre SP. 0,3	Dichtung für Zylinderfuß SP. 0,3	Junta base cilindro SP. 0,3
19.1	026110210 000	1		Guarnizione base cilindro SP. 0,4	Cylinder base gasket SP. 0,4	Garniture base cylindre SP. 0,4	Dichtung für Zylinderfuß SP. 0,4	Junta base cilindro SP. 0,4
19.2	026110220 000	1		Guarnizione base cilindro SP. 0,5	Cylinder base gasket SP. 0,5	Garniture base cylindre SP. 0,5	Dichtung für Zylinderfuß SP. 0,5	Junta base cilindro SP. 0,5
20	2900280 000	2		Tappo presa dep.	Air Vent Plug	Bouchon prise dep.	Verschluss f. Lufteinlass	Tapón Toma Aire dep.
21	3131050 000	2		Vite t.c.c.e.M6x15	Screw t.c.c.e.M6x15	Vis t.c.c.e.M6x15	Schraube t.c.c.e.M6x15	Tornillo t.c.c.e.M6x15
22	026020208 000	1	250cc	Pistone completo 250cc	Piston set 250cc	Piston compl. 250cc	Kolben, kompl. 250cc	Pistón, compl. 250cc
22	026020308 000	1	300cc	Pistone completo 300cc	Piston set 300cc	Piston compl. 300cc	Kolben, kompl. 300cc	Pistón, compl. 300cc
23	1616710 000	1		Gabbia	Cage	Cage	Lagerkä fig	Jaula
24	026110088 200	1	250cc	Kit gruppo termico 250cc	Thermal unit kit 250cc	Jeu groupe thermique 250cc	Satz für Thermischen Gruppe 250cc	Serie revisió n grupo té rmico 250cc
25	026110098 200	1	300cc	Kit gruppo termico 300cc	Thermal unit kit 300cc	Jeu groupe thermique 300cc	Satz für Thermischen Gruppe 300cc	Serie revisió n grupo té rmico 300cc
26	026110238 200	1		Serie guarnizioni gr. Termico	Set of gaskets thermal unit overhaul	Sé rie de joint du gr. thermique	Satz Dichtungen für Thermischen Gruppe	Serie juntas revisió n grupo té rmico
27	026110120 000	1		Tube sfciato	Breather tube	Tuyau ré niflard	Entlüftungsleitung	Tube respiradero

Tav.12

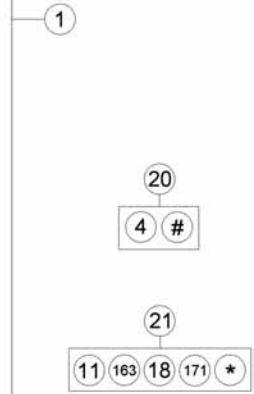
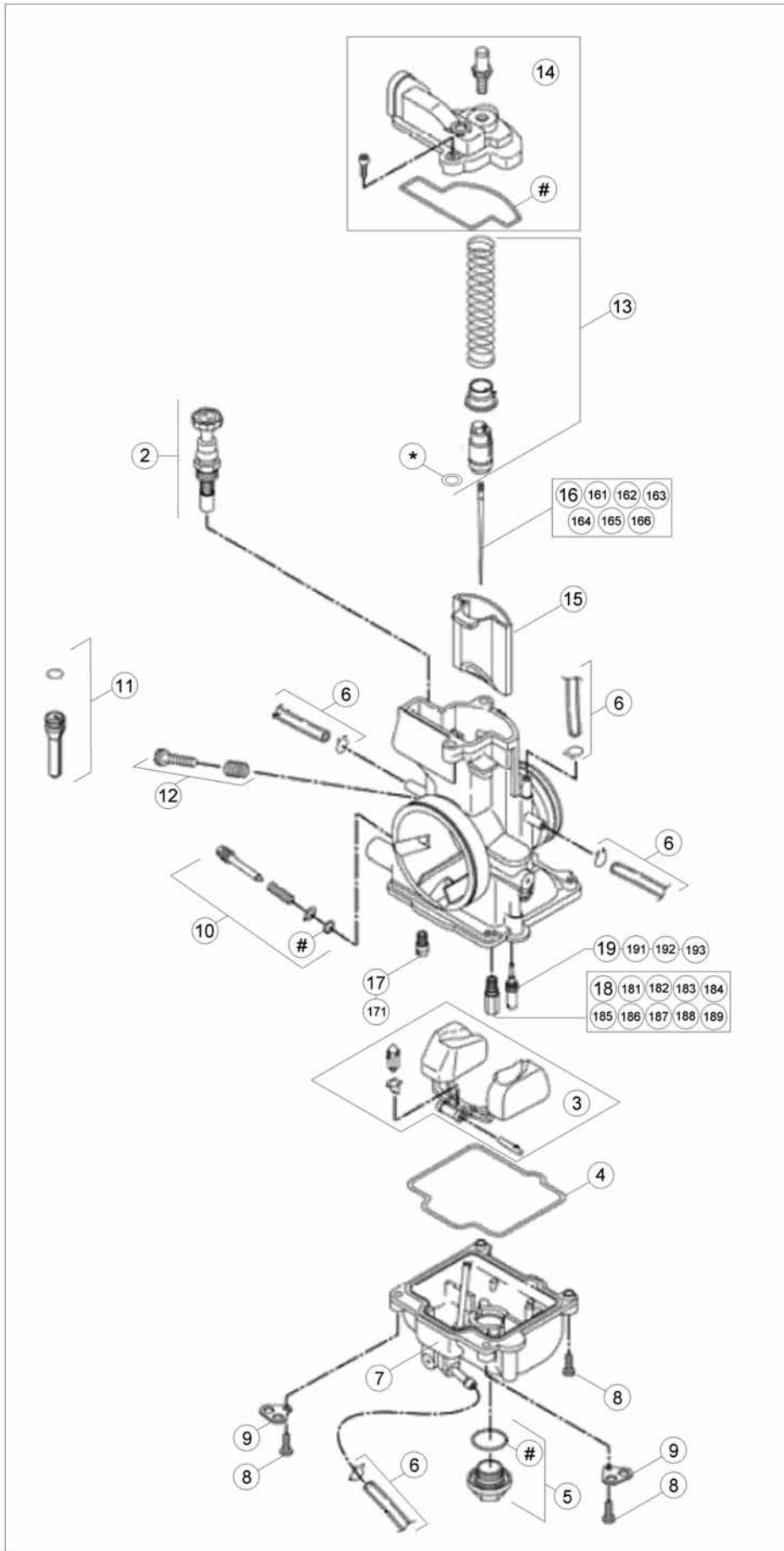

Beta
the play bike

Tav.12

Pos Loc Pos Ps Pos	Numero Number Numé ro Número Nummer	Q.tà Q.ty Q.té M.ge C.ad	Nota Note Note Nota Anm.	Descrizione	Description	Dé signation	Beschreibung	Descrìpò n
1	026120018 000	1	250cc	Carburatore KEIHIN	Carburettor KEIHIN	Carburateur KEIHIN	Vergaser KEIHIN	Carburador KEIHIN
1	026120008 000	1	300cc	Carburatore KEIHIN	Carburettor KEIHIN	Carburateur KEIHIN	Vergaser KEIHIN	Carburador KEIHIN
2	026120080 000	1		Pistone starter	Starter piston	Piston starter	Kolben starter	Pistón starter
3	026120098 000	1		Galleggiante	Float	Flotteur	Schwimmer	Flotador
4	026120110 000	1		Guarnizione vaschetta	Float chamber gasket	Joint vase essence	Dichtung Schwimmergehäuse	Junta cuba
5	026120128 000	1		Tappo vaschetta	Cap drain	Bouchon	Verschluss	Tapón
6	026120450 000	1		Kit tubi sfciato	Breather pipes kit	Kit tuyaux reniflard	Kit Entlüftungsleitungen	Kit tubos respiraderos
7	026120150 000	1		Vaschetta completa	Chamber assy.	Cuvette compl.	Becken kpl	Cubeta compl.
8	026120160 000	3		Vite M4x16	Screw M4x16	Vis M4x16	Schraube M4x16	Tornillo M4x16
9	026120240 000	2		Piastrina	Plate	Plaquette	Plättchen	Placa
10	026120288 000	1		Vite di regolazione	Adjusting screw	Vis de réglage	Schraube, Einstell	Tornillo de regul.
11	026120068 000	1		Distanziale	Spacer	Entretoise	Distanzstück	Distancidor
12	026120328 000	1		Vite di regolazione	Adjusting screw	Vis de réglage	Schraube, Einstell	Tornillo de regul.
13	026120378 000	1		Molla valvola	Valve spring	Ressort soupape	Ventilfeder	Muelle válvula
14	026120398 000	1		Coperchio carburatore	Carburettor cover	Couvercle carburateur	Abdeckung Vergaser	Tapa carburador
15	026120410 000	1		Valvola Carburatore	Carb Valve	Soupape Carburateur	Vergaserventil	Válvula Carb.
16	026120190 000	1	300cc	Spillo N2ZJ	Needle N2ZJ	Pointeau N2ZJ	Düsenadel N2ZJ	Aguja N2ZJ
161	026120180 000	1	300cc	Spillo N2ZW	Needle N2ZW	Pointeau N2ZW	Düsenadel N2ZW	Aguja N2ZW
162	026120200 000	1	300cc	Spillo N2ZK	Needle N2ZK	Pointeau N2ZK	Düsenadel N2ZK	Aguja N2ZK
163	026120170 000	1	OMOLOG	Spillo N84K	Needle N84K	Pointeau N84K	Düsenadel N84K	Aguja N84K
164	026120210 000	1	300cc	Spillo N2ZH	Needle N2ZH	Pointeau N2ZH	Düsenadel N2ZH	Aguja N2ZH
165	026120220 000	1	250cc	Spillo NOZK	Needle NOZK	Pointeau NOZK	Düsenadel NOZK	Aguja NOZK
166	026120230 000	1	250cc	Spillo NOZJ	Needle NOZJ	Pointeau NOZJ	Düsenadel NOZJ	Aguja NOZJ
17	026120460 000	1		Getto starter 85	Starter jet 85	Gicleur starter 85	Starterdüse 85	Surtidor starter 85
171	026120050 000	1	OMOLOG	Getto starter 50	Starter jet 50	Gicleur starter 50	Starterdüse 50	Surtidor starter 50
18	1642304 000	1	OMOLOG	Getto massimo 118	Main jet 118	Gicleur maxi 118	Hauptdüse 118	Surtidor máximo 118
181	3625104 000	1		Getto massimo 155	Main jet 155	Gicleur maxi 155	Hauptdüse 155	Surtidor máximo 155
182	3625105 000	1		Getto massimo 158	Main jet 158	Gicleur maxi 158	Hauptdüse 158	Surtidor máximo 158
183	3625106 000	1		Getto massimo 160	Main jet 160	Gicleur maxi 160	Hauptdüse 160	Surtidor máximo 160
184	3625107 000	1		Getto massimo 162	Main jet 162	Gicleur maxi 162	Hauptdüse 162	Surtidor máximo 162
185	3625108 000	1		Getto massimo 165	Main jet 165	Gicleur maxi 165	Hauptdüse 165	Surtidor máximo 165
186	3625109 000	1		Getto massimo 168	Main jet 168	Gicleur maxi 168	Hauptdüse 168	Surtidor máximo 168
187	3625110 000	1		Getto massimo 170	Main jet 170	Gicleur maxi 170	Hauptdüse 170	Surtidor máximo 170
188	3625111 000	1		Getto massimo 172	Main jet 172	Gicleur maxi 172	Hauptdüse 172	Surtidor máximo 172
189	3625112 000	1		Getto massimo 175	Main jet 175	Gicleur maxi 175	Hauptdüse 175	Surtidor máximo 175
19	1642357 000	1	250cc	Getto minimo 35	Starter jet 35	Gicleur starter 35	Starterdüse 35	Surtidor starter 35
191	1642355 000	1	300cc	Getto minimo 38	Starter jet 38	Gicleur starter 38	Starterdüse 38	Surtidor starter 38
192	026120070 000	1		Getto minimo 40	Starter jet 40	Gicleur starter 40	Starterdüse 40	Surtidor starter 40
193	1642347 000	1		Getto minimo 42	Starter jet 42	Gicleur starter 42	Starterdüse 42	Surtidor starter 42
20	026120440 000	1		Kit guarnizioni	Packings kit	Jeu joints	Dichtungensatz	Grupo juntas
21	026450048 000	1	300cc	Kit carburatore OMOLOGAZIONE	Carburetor kit HOMOLOGATION	Kit carburateur HOMOLOGATION	Vergaser Kit ZULASSUNGS	Kit carburador HOMOLOGACIÓN
21	026450038 000	1	250cc	Kit carburatore OMOLOGAZIONE	Carburetor kit HOMOLOGATION	Kit carburateur HOMOLOGATION	Vergaser Kit ZULASSUNGS	Kit carburador HOMOLOGACIÓN

Tav.14

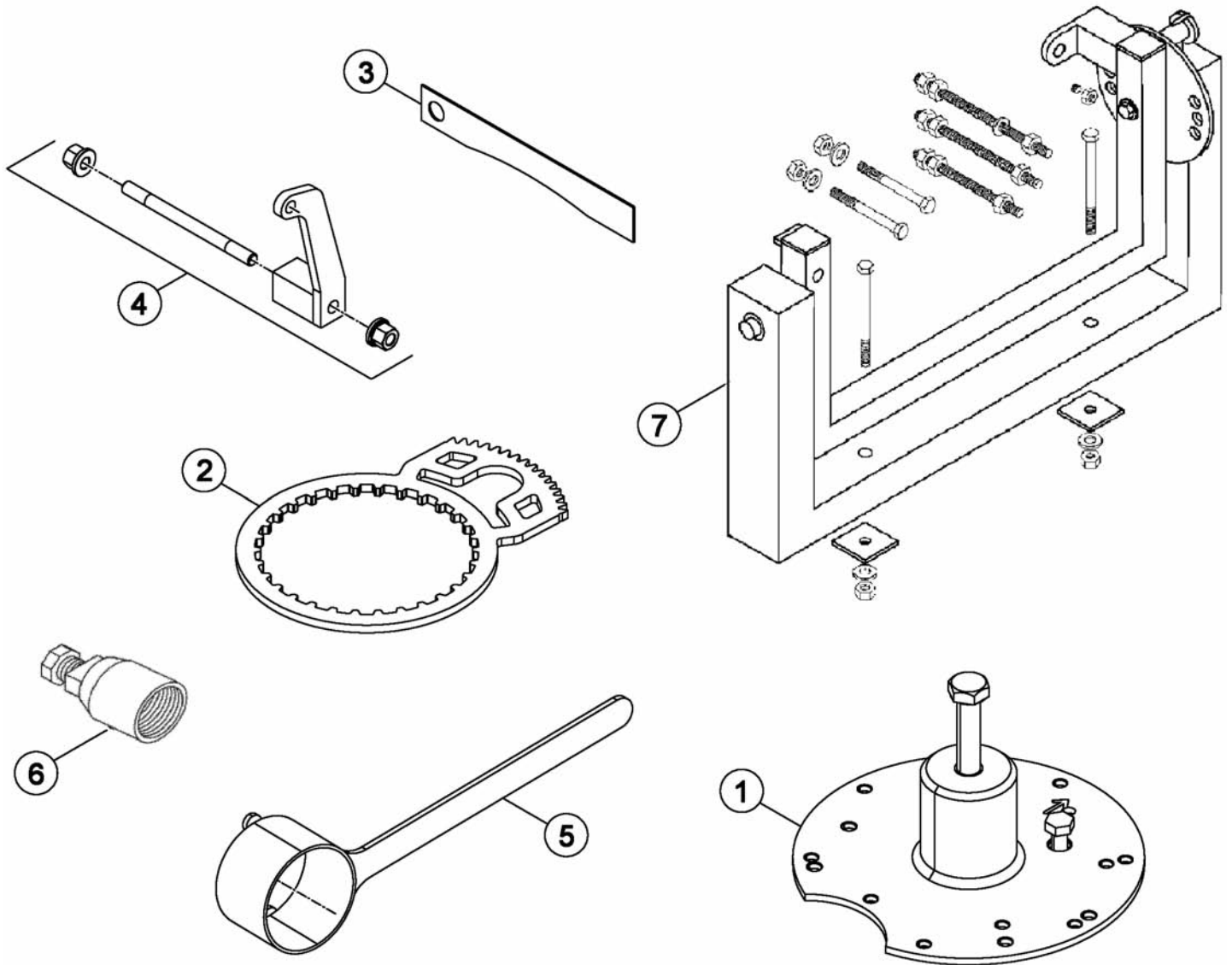

Beta
the play bike

Tav.14

Pos Loc Pos Ps Pos	Numero Number Numé ro Número Nummer	Q.tà Q.ty Q.té M.ge C.ad	Nota Note Nota Nota Anm.	Descrizione	Description	Dé signation	Beschreibung	Descrìciò n
1	007140108 000	1		Disaccoppiatore carter	Crankcase splitter	Sé parateur de carter	Entkoppler gehä use	Desacoplador del cárter
2	026140010 000	1		Attrezzo bloccaggio trasmissione primaria	Holding Tool, Primary drive	Clé de fixation de la transmission principale	Halteschlü ssel für Hauptantrieb	Llave para bloquear la transmisión primaria
3	026140020 000	1		Strumento misura squish	Squish measuring tool	Outil de mesure du squish	Werkzeug für Quetschkante ausmessen	Herramienta para medir el squish
4	026140030 000	1		Staffa supporto motore	Engine support bracket	Bride support moteur	Motorsattelbefestigung	Brida soporte motor
5	026140040 000	1		Attrezzo bloccaggio volante	Holding Tool, Flywheel	Clé de fixation volant	Halteschlü ssel für Schwungrad	Llave para sostener el volante
6	3625173 000	1		Estrattore volante	Flywheel extractor	Extracteur pour volant	Auszieher für Schwungrad	Extractor volante
7	3625132 000	1		Attrezzatura Mont. Motore	Mounting Rack	Outils Montage Moteur	Montagebock	Aparejos Montaje Motor

Tav.31

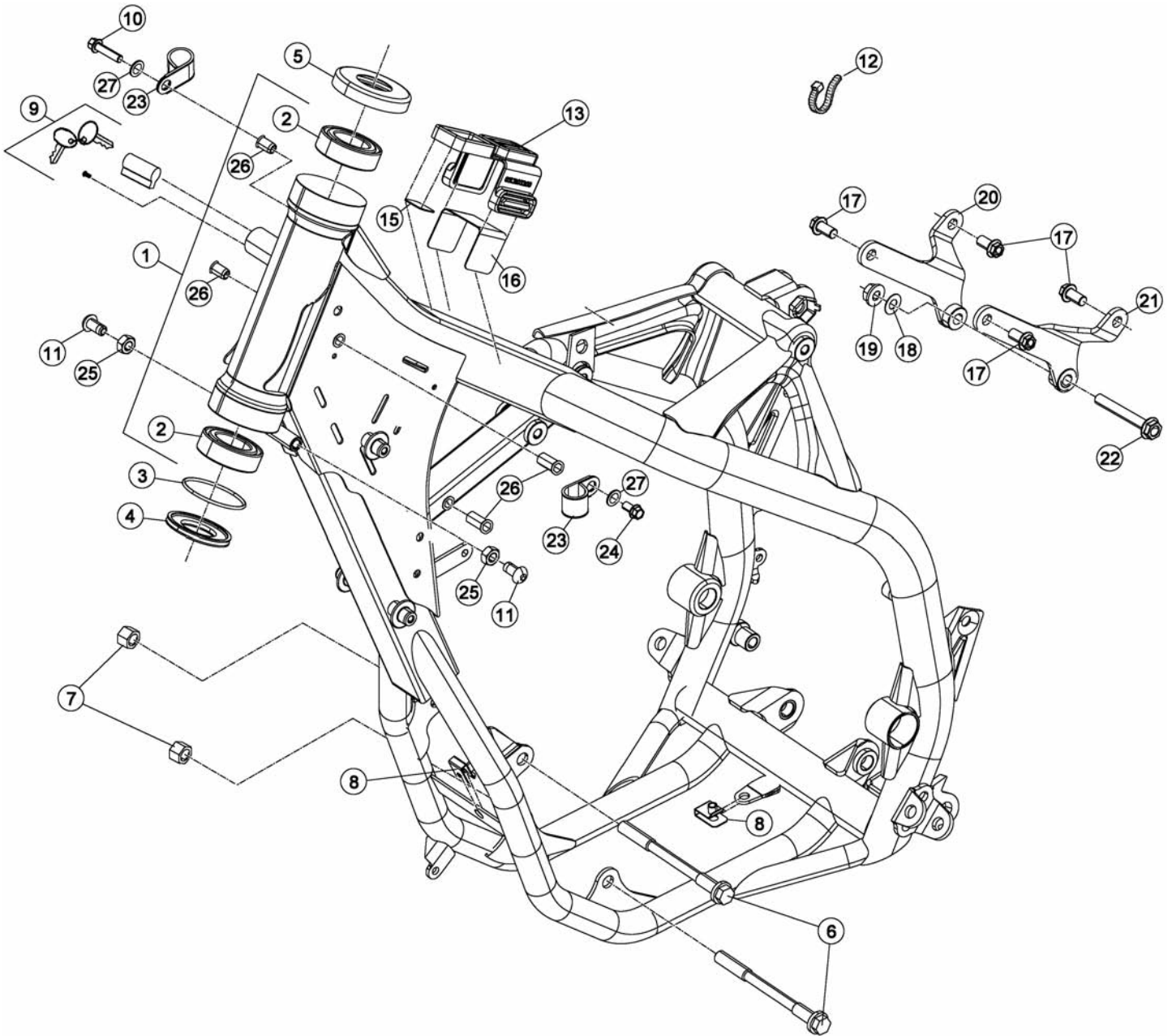

Beta
the play bike

Tav.31

Pos Loc Ps Pos	Numero Number Numéro Número Nummer	Q.tà Q.ty Q.té M.ge C.ad	Nota Note Note Nota Anm.	Descrizione	Description	Dé signation	Beschreibung	Descrìpziò n
1	026310508 050	1		Telaio completo	Frame, assy	Chassis complet	Rahmen, kpl	Bastidor compl.
2	1299510 000	2		Cuscinetto conico 29x50x15	Conical bearing 29x50x15	Roulement conique 29x50x15	Lager 29x50x15	Cojnete conico 29x50x15
3	1066935 000	1		Anello OR	O-Ring	Bague d' é tanché ité	O-Ring	Anillo OR
4	020310390 000	1		Anello parapolvere	Dust cover	Disque pare-poussié re	Staubdeckel	Disco gurdapolvo
5	2598782 000	1		Protezione cuscinetto	End Cap Bearing	Palier De Bielle	Lagerdeckel	Tapa Rodamiento
6	1164607 000	2		Perno motore	Engine pin	Axe moteur	Motorbolzen	Perno motor
7	1321060 000	2		Dado M10x1,25	Nut M10x1,25	Ecrou M10x1,25	Mutter M10x1,25	Tuerca M10x1,25
8	2560311 000	2		Piastrina elastica M6	Spring plate M6	Plaque é lastique M6	Plättchen M6	Pletina elástica M6
9	2885861 000	1		Serratura bloccasterzo	Security lock	Serrure blocage guidon	Lenkradschloss	Cerradura bloque manillar
10	1150010 000	1		Bullone M6x25	Bolt M6x25	Boulon M6x25	Bolzen M6x25	Tornillo M6x25
11	3164060 000	2		Vite TBCE M8X16	Screw TBCE M8X16	Vis TBCE M8X16	Schraube TBCE M8X16	Tornillo TBCE M8X16
12	1514264 000	1		Fascetta	Clamp	Collier	Schelle	Abrazadera
13	031310330 000	1		Tampone anteriore serbatoio	Front buffer tank	Silentbloc AV. ré servoir	Puffer tank	Silent-block del. deposito
15	020310340 000	1		Adesivo anteriore	Front sticker	Dé calcomanie AV.	Vorderer Kleber	Pega delantero
16	020310350 000	1		Adesivo posteriore	Rear sticker	Dé calcomanie AR.	Hinterer Kleber	Pega trasero
17	1154521 000	4		Bullone M8x16	Bolt M8x16	Boulon M8x16	Bolzen M8x16	Tornillo M8x16
18	2749500 000	1		Rondella 8x18	Washer 8x18	Rondelle 8x18	U.Scheibe 8x18	Arandela 8x18
19	1317123 000	1		Dado M8 flangiato	Nut M8	Ecrou M8	Mutter M8	Tuerca M8
20	026310448 000	1		Staffa attacco testa dx.	Head connection bracket R.H.	Bride attelage culasse D.	Befestigung Zylinderkopf R.	Brida anclaje culata der.
21	026310458 000	1		Staffa attacco testa sx.	Head connection bracket L.H.	Bride attelage culasse G.	Befestigung Zylinderkopf L.	Brida anclaje culata izq.
22	1155950 000	1		Vite M8x60	Screw M8x60	Vis M8x60	Schraube M8x60	Tornillo M8x60
23	2525180 000	2		Passacavo	Grommet	Passe-câ ble	Kabeldurchgang	Pasacables
24	1147015 000	1		Bullone M6x12	Bolt M6x12	Boulon M6x12	Bolzen M6x12	Tornillo M6x12
25	1316000 000	2		Dado M8x6	Nut M8x6	Ecrou M8x6	Mutter M8x6	Tuerca M8x6
26	2733741 000	4		Rivetto	Rivet	Rivet	Niete	Remache
27	2740500 000	2		Rondella 6x13	Washer 6x13	Rondelle 6x13	U.Scheibe 6x13	Arandela 6x13

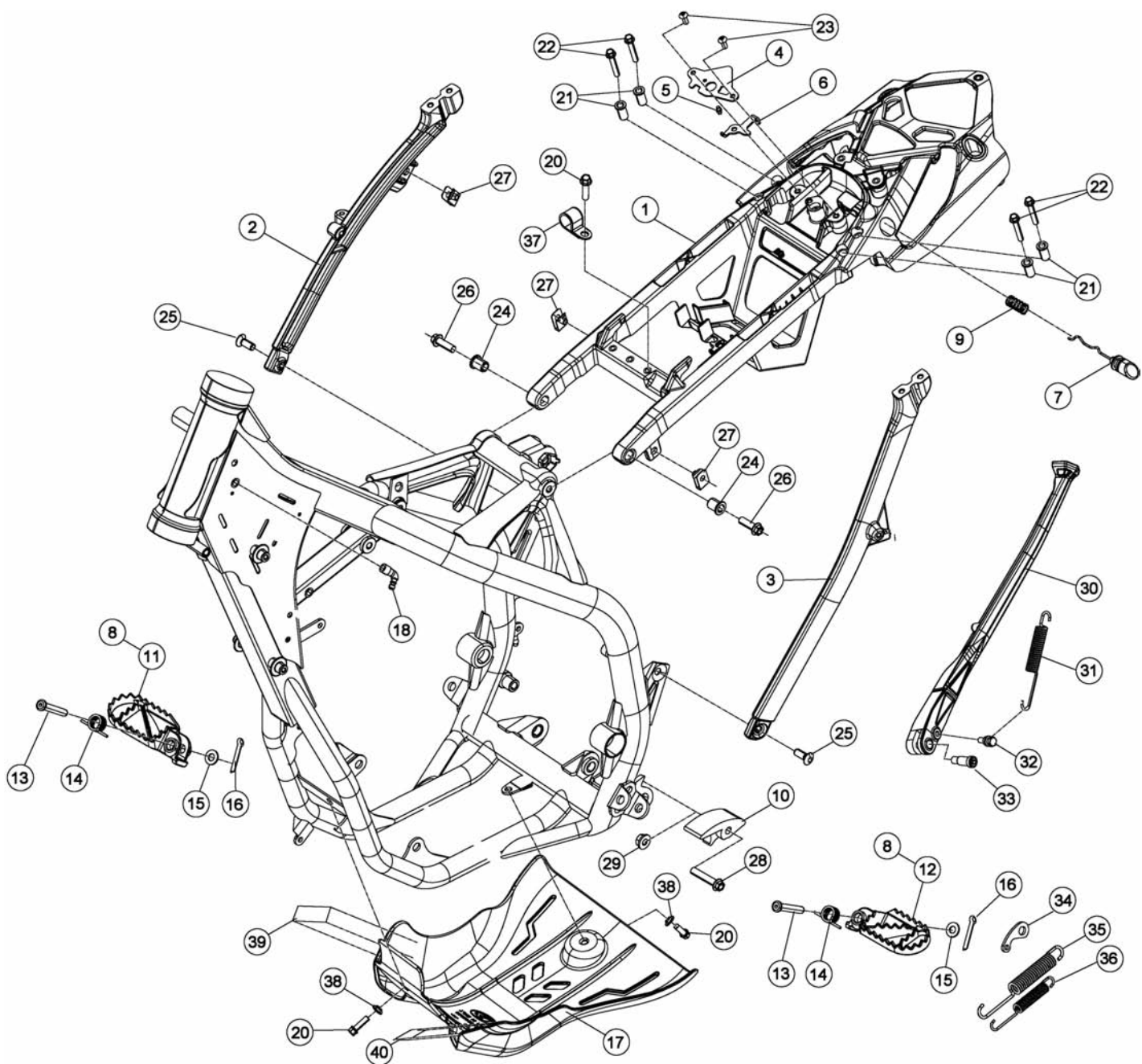

Tav.32

Pos Loc Pos Ps Pos	Numero Number Numéro Número Nummer	Q.tà Q.ty Q.té M.ge C.ad	Nota Note Nota Anm.	Descrizione	Description	Dé signation	Beschreibung	Descrìpziò n
1	031320001 059	1		Telaietto posteriore	Rear frame	Châ ssis arriè re	Hinterer kleiner Rahmen	Bastidor trasero
2	020321000 059	1		Braccetto destro	Right arm	Bras droit	Rechter Schutzblecharm	Brazo derecho
3	020321010 059	1		Braccetto sinistro	Left arm	Bras gauche	Linker Schutzblecharm	Brazo izquierdo
4	020320100 005	1		Piastra fissaggio serratura	Lock sec. Plate	Plaque fix. Serrure	Befestigungsplatte Schloß	Chapa fij. cerradura
5	020321120 000	1		Perno serratura	Pin	Pivot	Zapfen	Perno
6	020320110 005	1		Piasta ritegno serratura	Plate	Plaquette	Schild	Placa
7	020320138 000	1		Bottone	Knob	Bouton	Knopf	Boton
8	020450758 000	1	RACING	Coppia pedane poggiapiedi	Foot-peg, couple	Couple repose-pieds	FuBblechpaar	Par de estribos
9	020320160 000	1		Molla	Spring	Ressort	Feder	Muelle
10	2525601 000	1		Pattino catena	Chain shoe	Doigt chaine	Gleitauflage	Pati n catena
11	2532521 000	1		Pedana dx.	Foot-peg R.H.	Repose-pieds d.	FuBblech rechts	Estribo der.
12	2532531 000	1		Pedana sx.	Foot-peg L.H.	Repose-pieds g.	FuBblech links	Estribo izq.
13	2554465 000	2		Perno pedana	Footrest pin	Pivot repose-pied	Rasten Pin	Eje estribera
14	016320200 000	2		Molla pedanina	Foot rest spring	Ressort repose-pied	FuBblechfeder	Muelle estribo
15	031320010 000	2		Rondella 10x21x2	Washer 10x21x2	Rondelle 10x21x2	U.Scheibe 10x21x2	Arandela 10x21x2
16	1281993 000	2		Copiglia 3x20	Split pin 3x20	Goupille 3x20	Splint 3x20	Grupilla 3x20
17	026320200 000	1		Protezione motore	Engine protection	Protection moteur	Motorschutz	Protecció n motor
18	2723470 000	1		Raccordo per sfiato	Breather pipe	Raccord pour vidange	Entlü ftungsrohranschluß	Racor para ventilació n
20	1149070 000	3		Bullone 6x20 ch rs	Bolt 6x20 ch rs	Boulon 6x20 ch rs	Bolzen 6x20 ch rs	Tornillo 6x20 ch rs
21	020320040 000	4		Boccola superiore	Upper bush	Douille supé rieur	Obere Buchse	Casquillo superior
22	1150355 000	4		Bullone M6x35	Bolt M6x35	Boulon M6x35	Bolzen M6x35	Tornillo M6x35
23	3129810 000	2		Vite 5x12	Screw 5x12	Vis 5x12	Schraube 5x12	Tornillo 5x12
24	020320030 000	2		Boccola anteriore	Front bush	Douille avant	Vordere Buchse	Casquillo delantero
25	007320320 000	2		Vite speciale TSBEI	Special screw TSBEI	Vis spé ciale TSBEI	Spezi schraube TSBEI	Tornillo especial TSBEI
				CH6 M8x20 10.9 zinc	CH6 M8x20 10.9 zinc	CH6 M8x20 10.9 zinc	CH6 M8x20 10.9 zinc	CH6 M8x20 10.9 zinc
26	3164070 000	2		Vite flangiata 8x30	Flanged screw 8x30	Vis à brides 8x30	Flanschschraube 8x30	Tornillo rebordado 8x30
27	2560311 000	3		Piastrina elastica M6	Spring plate M6	Plaquette é lastique M6	Plättchen M6	Pletina elástica M6
28	1155480 000	1		Vite M8x40	Screw M8x40	Vis M8x40	Schraube M8x40	Tornillo M8x40
29	1317020 000	1		Dado autoblocc. Basso M8	Nut M8	Ecrou M8	Mutter M8	Tuerca M8
30	031320700 000	1		Cavalletto	Central stand	Bé quille	Kippstä nder	Caballete
31	020320260 000	1		Molla cavalletto	Central stand spring	Ressort bé quille	Feder Kippstä nder	Muelle caballete
32	1166615 000	1		Bullone spec. piastra cavalletto	Central stand special bolt	Boulon spec. plaque bé q.	Spezi schraube Kippstä nderplatte	Tornillo especial chapa caballete
33	1166614 000	1		Bullone spec. cavalletto	Special bolt	Boulon spec.	Spezi schraube	Tornillo especial
34	2557636 000	1		Piastrina aggancio molla	Bracket spring	Plaquette accroch. ressort	Plättchen federanlenkung	Placa eng. muelle
35	2248819 000	1		Molla esterna	Spring	Ressort	Feder	Muelle
36	2248818 000	1		Molla interna	Spring	Ressort	Feder	Muelle
37	1514654 000	1		Fascetta	Clamp	Collier	Schelle	Abrazadera
38	1354820 000	2		Distanziale 6,5x9,0x13,5	Spacer 6,5x9,0x13,5	Entretoise 6,5x9,0x13,5	Distanzstück 6,5x9,0x13,5	Distanciador 6,5x9,0x13,5
39	026320210 000	1		Tampone (lato destro)	Buffer (right side)	Silentbloc (Cò té droit)	Puffer (Rechte Seite)	Tampó n (Lado derecho)
40	026320220 000	1		Tampone (lato sinistro)	Buffer (left side)	Silentbloc (Cò té gauche)	Puffer (Linke Seite)	Tampó n (Lado izquierdo)

Tav.33A

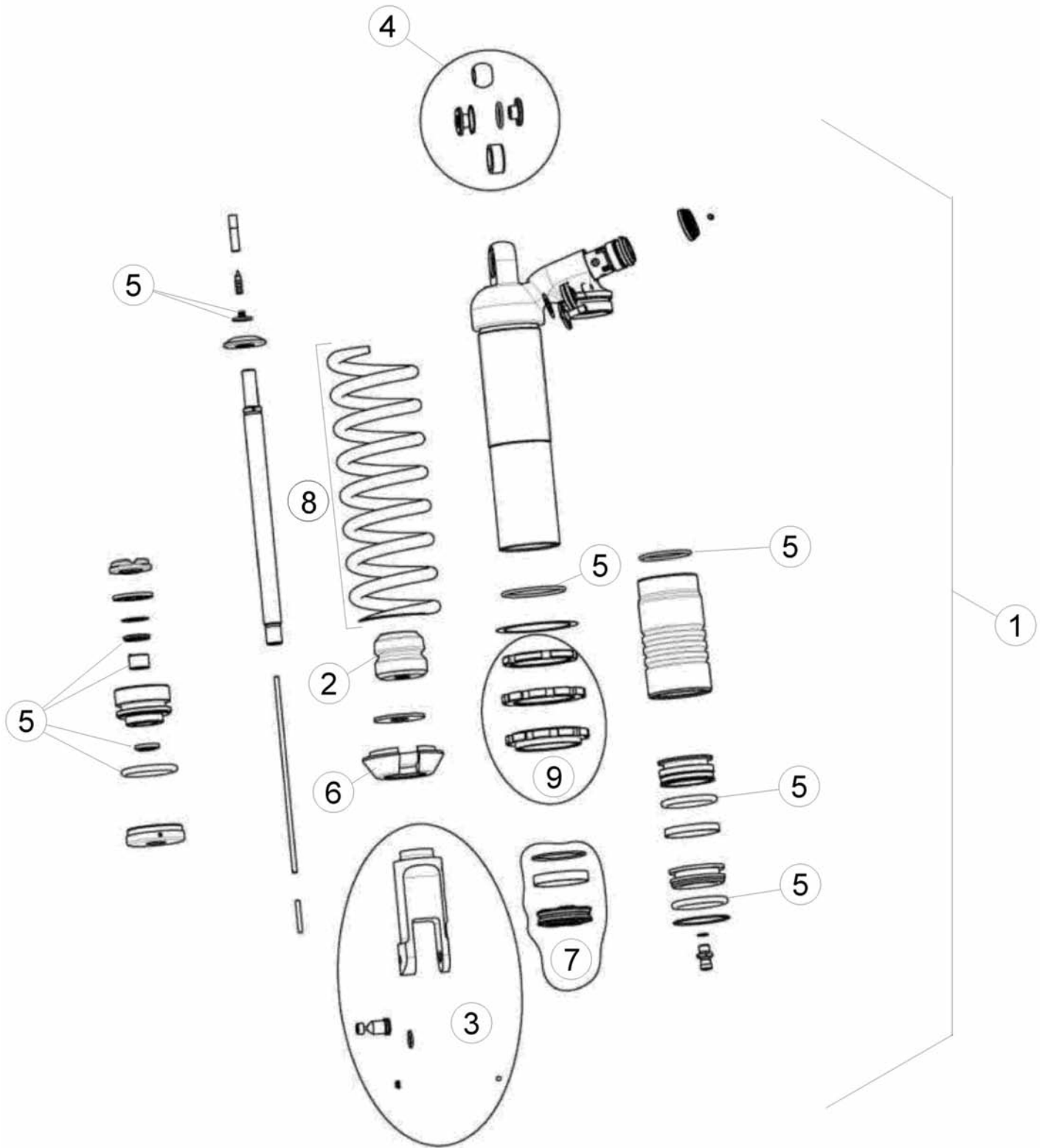

Tav.33A

Pos Loc Pos Ps Pos	Numero Number Numéro Número Nummer	Q.tà Q.ty Q.té M.ge C.ad	Nota Note Note Nota Anm.	Descrizione	Description	Dé signation	Beschreibung	Descrìciò n
1	026331008 000	1		Ammortizzatore completo	Shock absorber assembly	Amortisseur complet	Stoßdämpfer komplett	Amortiguador completo
2	020331410 000	1		Tampone	Buffer	Silentbloc	Puffer	Silent-block
3	020331420 000	1		Gruppo forchetta ammortizz.	Shock absorber inf. Connection	Fixation inférieure amortisseur	Untere Befestigung Stossdämpfer	Fijador inferior amortiguador
4	1386078 800	1		Kit distanziali ammortizzatore	Damper spacer kit	Jeu entretoises amortisseur	Kit Stoßdämpfer Distanz	Juego distanciador amortiguador
5	031330440 000	1		Gruppo guarnizioni	Gasket set	Groupe garnitures	Dichtungssatz	Grupo juntas
6	1539110 000	1		Fondello	Cup	Godet	Deckel	Cazoleta
7	031330460 000	1		Pistone completo	Piston set	Piston compl.	Kolben, kompl.	Pistón, compl.
8	026330020 000	1	STD	Molla	Spring	Ressort	Feder	Muelle
9	031330450 000	1		Gruppo ghiera	Ring nuts	Douilles	Gewinderingen	Casquillos



Tav.33B

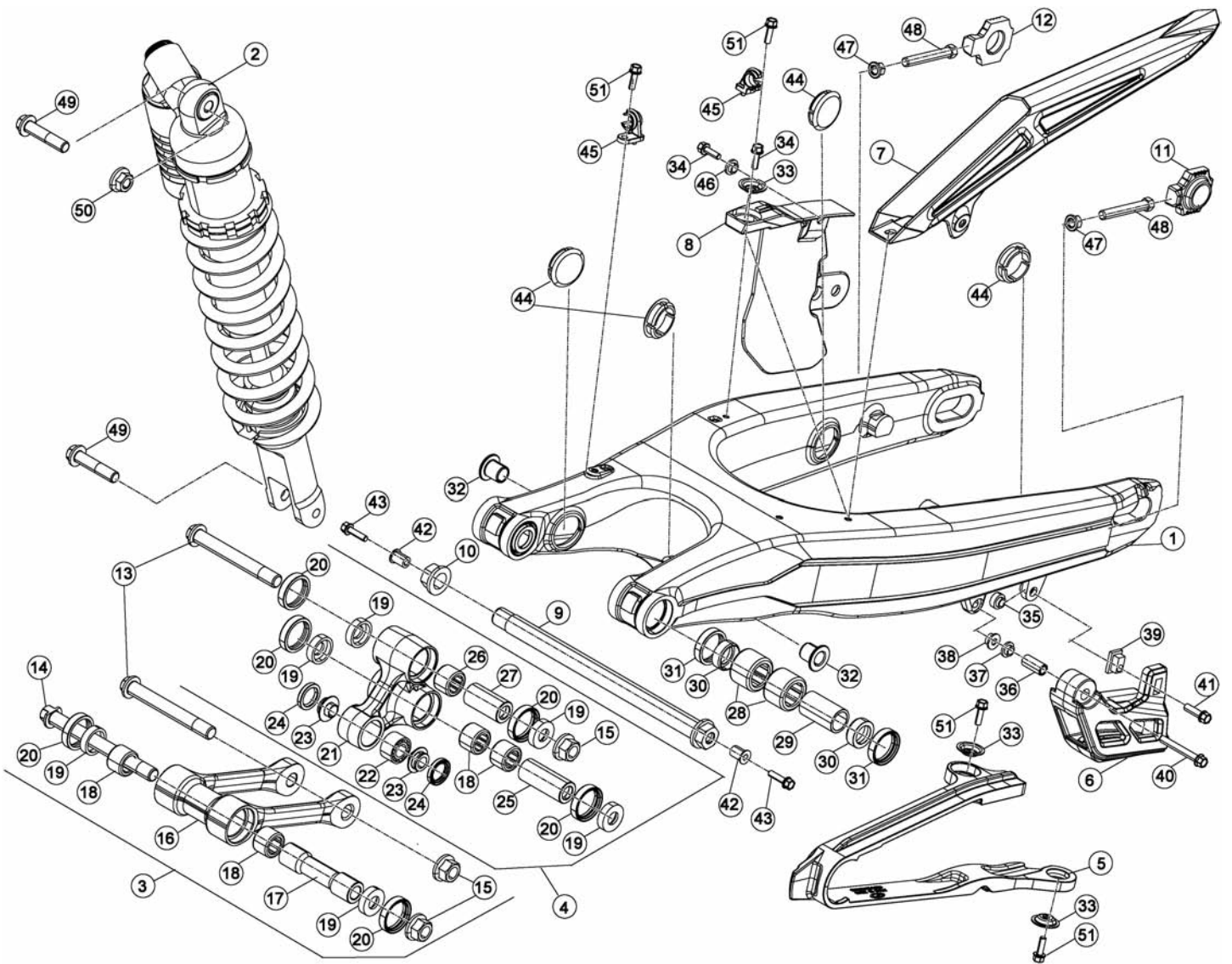

Tav.33B

Pos Loc Ps Pos	Numero Number Numéro Nummer	Q.tà Q.ty Q.té M.ge C.ad	Nota Note Note Nota Anm.	Descrizione	Description	Dé signation	Beschreibung	Descrìpò n
1	031330000 059	1		Forcellone	Big fork	Fourche	Radschwinge	Horquilla
2	026331008 000	1		Ammortizzatore completo	Shock absorber assembly	Amortisseur complet	Stoßdämpfer komplett	Amortiguador completo
3	020330308 000	1		Biellecca	Connecting rod	Biellette	Bolzensange	Bieleca
4	020330208 000	1		Bilanciere	Lever	Balancier	Kipphebel	Balancin
5	020330150 059	1		Tassello guidacatena super.	Upper sliding block	Chevillie guide de chaîne sup.	Schwingschleifklotz oben	Protector catena superior
6	2910071 000	1		Tassello guidacatena infer.	Lower sliding block	Chevillie guide de chaîne inf.	Schwingschleifklotz unten	Protector catena inferior
7	1288591 159	1		Copricatena superiore	Up. Chain cover	Couvre-chaîne superieur	Kettenschutz oben	Cubrecadena superior
8	1288594 159	1		Copricatena inferiore	Lower chain cover	Couvre-chaîne inferieur	Kettenschutz unten	Cubrecadena inferior
9	2547652 000	1		Perno forcellone	Swingarm pivot	Axe fourche AR.	Schwingbolzen	Eje basculante
10	1327121 000	1		Dado speciale	Special nut	Ecrou spéciale	Spezialmutter	Tuerca especial
11	2911866 100	1		Tendicatena SX	Chain adjuster L.	Tendeur de chaîne G.	Kettenspanne L.	Tensor de cadena l.
11	031330034 250	1	RACING	Tendicatena SX	Chain adjuster L.	Tendeur de chaîne G.	Kettenspanne L.	Tensor de cadena l.
12	2911865 100	1		Tendicatena DX	Chain adjuster R.	Tendeur de chaîne D.	Kettenspanner R.	Tensor de cadena D.
12	031330024 250	1	RACING	Tendicatena DX	Chain adjuster R.	Tendeur de chaîne D.	Kettenspanner R.	Tensor de cadena D.
13	1163992 000	2		Vite speciale M12	Special screw M12	Vis spéciale M12	Spezialschraube M12	Tornillo especial M12
14	020330320 000	1		Vite speciale M12	Special screw M12	Vis spéciale M12	Spezialschraube M12	Tornillo especial M12
15	1321130 000	3		Dado autobloccante M12	Self locking nut M12	Ecrou de sécurité M12	Mutter, selbstsichernd M12	Tuerca de seguridad M12
16	020330300 000	1		Biellecca	Connecting rod	Biellette	Bolzensange	Bieleca
17	020330310 000	1		Distanziale	Spacer	Entretoise	Distanzstück	Distanciadador
18	1122055 000	4		Boccola a rulli 20x26x16	Roller bearing 20x26x16	Douille à roulements 20x26x16	Rollenbuchse 20x26x16	Caja de grasa de rodillos 20x26x16
19	2814083 000	6		Scodellino	Stop washer	Rondelle d'ar	Federaufnahme	Platillo
20	1064481 000	6		Paraolio	Oil seal	Pare-huile	Dichtring	Sello de lub.
21	020330200 000	1		Bilanciere	Lever	Balancier	Kipphebel	Balancin
22	1617310 000	1		Boccola a rulli 12x24x30	Roller bearing 12x24x30	Douille à roulements 12x24x30	Rollenbuchse 12x24x30	Caja de grasa de rodillos 12x24x30
23	1121920 000	2		Boccola	Bush	Moyeu	Büchse	Buje
24	1056020 000	2		Paraolio 16x24x4	Oil seal 16x24x4	Pare-huile 16x24x4	Dichtring 16x24x4	Sello de lub. 16x24x4
25	1362813 000	1		Distanziale 12x20x50	Spacer 12x20x50	Entretoise 12x20x50	Distanzstück 12x20x50	Distanciadador 12x20x50
26	1122061 000	1		Boccola a rulli 20x26x30	Roller bearing 20x26x30	Douille à roulements 20x26x30	Rollenbuchse 20x26x30	Caja de grasa de rodillos 20x26x30
27	1362812 000	1		Distanziale 12x20x40	Spacer 12x20x40	Entretoise 12x20x40	Distanzstück 12x20x40	Distanciadador 12x20x40
28	1122056 000	4		Boccola a rullini 22x28x12	Roller cage 22x28x12	Cage Aiguille 22x28x12	Rollenkäfig 22x28x12	Jaula rodillos 22x28x12
29	1349183 000	2		Distanziale forcellone	Big fork spacer	Entretoise fourche	Distanzstück Radschwinge	Distanciadador horquilla
30	2814081 000	4		Scodellino	Stop washer	Rondelle d'ar	Federaufnahme	Platillo
31	1064481 000	4		Paraolio	Oil seal	Pare-huile	Dichtring	Sello de lub.
32	020330010 000	2		Boccola	Bush	Moyeu	Büchse	Buje
33	2774786 000	3		Rondella bombata	Kasher	Rondelle	Scheibe	Arandela
34	1146360 000	2		Bullone flangiato M5x16	Head Flanged bolt M5x16	Boulon Bridé M5x16	Bundbolzen M5x16	Bulón con Brida M5x16
35	1312610 000	1		Dado	Nut	Ecrou	Mutter	Tuerca
36	1349191 000	1		Distanziale	Spacer	Entretoise	Distanzstück	Distanciadador
37	1354820 000	1		Distanziale 6,5x9,0x13,5	Spacer 6,5x9,0x13,5	Entretoise 6,5x9,0x13,5	Distanzstück 6,5x9,0x13,5	Distanciadador 6,5x9,0x13,5
38	1313020 000	1		Dado autobloccante M6	Self locking nut M6	Ecrou de sécurité M6	Mutter, selbstsichernd M6	Tuerca de seguridad M6
39	1348868 000	1		Distanziale tassello guidacatena	Sliding block spacer	Entretoise cheville guide de chaîne	Abstandstück Schwingschleifklotz	Separador protector cadena/basculante
40	1105535 000	1		Bullone 6.50 rs ch 8	Bolt 6.50 rs ch 8	Boulon 6.50 rs ch 8	Bolzen 6.50 rs ch 8	Tornillo 6.50 rs ch 8
41	1149070 000	1		Bullone 6x20 ch rs	Bolt 6x20 ch rs	Boulon 6x20 ch rs	Bolzen 6x20 ch rs	Tornillo 6x20 ch rs
42	2733740 000	2		Rivetto filettato M6	Threaded rivet M6	Rivet fileté M6	Niete mit gewinde M6	Remache roscado M6
43	1146401 000	2		Bullone M5x20	Bolt M5x20	Boulon M5x20	Bolzen M5x20	Tornillo M5x20
44	2910596 136	4		Tappo forcellone D30	Big fork plug D30	Bouchon fourche D30	Radschwinge verschluß D30	Tapón horquilla D30
45	1514605 000	2		Passatubo	Grommet	Passe-tube	Rohrdurchgang	Pasa-tubo
46	1354820 000	1		Distanziale 6,5x9,0x13,5	Spacer 6,5x9,0x13,5	Entretoise 6,5x9,0x13,5	Distanzstück 6,5x9,0x13,5	Distanciadador 6,5x9,0x13,5
47	1317121 000	2		Dado speciale M8	Special nut M8	Ecrou spéciale M8	Spezialmutter M8	Tuerca especial M8
48	1155909 000	2		Bullone M8x55	Bolt M8x55	Boulon M8x55	Bolzen M8x55	Tornillo M8x55
49	1162050 000	2		Bullone fiss. ammortizzatore M10x45	Damper sec. bolt M10x45	Boulon fix. amortisseur M10x45	Befestigungsbolzen M10x45	Tornillo fij amortiguador M10x45
50	1321050 000	1		Dado flangiato M10X1,25	Flanged nut M10X1,25	Ecrou bordé M10X1,25	Flanschmutter M10X1,25	Tuerca embreada M10X1,25
51	1146251 000	4		Bullone flangiato M5x12	Head Flanged bolt M5x12	Boulon Bridé M5x12	Bundbolzen M5x12	Bulón con Brida M5x12

Tav.34

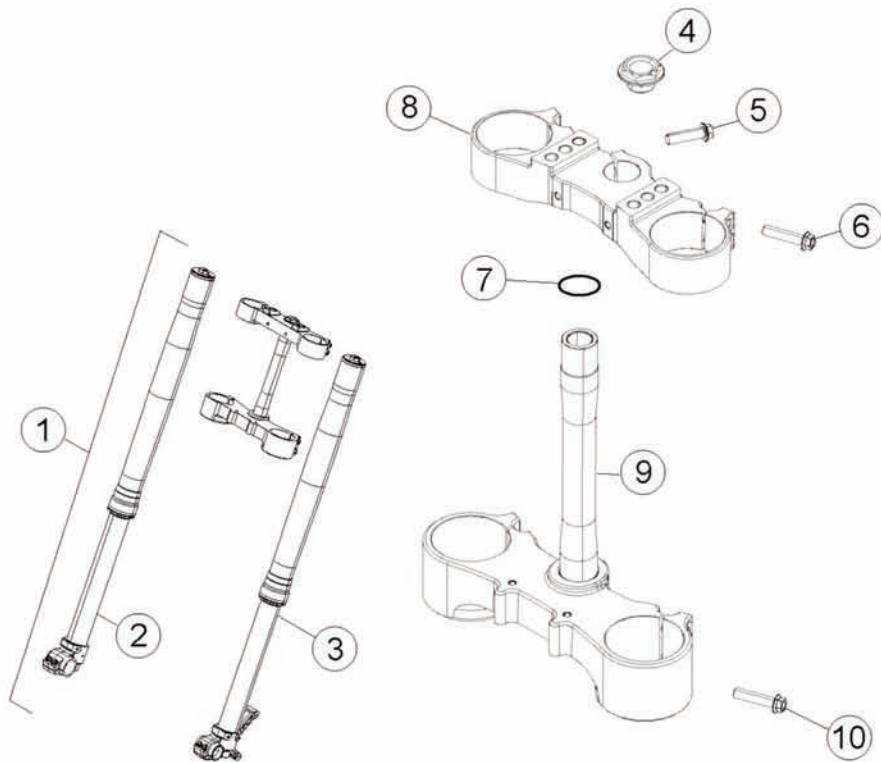



- Olio forcella
- Fork oil
- Gabelöl
- Huile de fourche
- Aceite de horquilla

BETA consiglia:
 BETA recommends:
 BETA empfohlen:
 BETA recommande:
 BETA recomienda:

SAE 6,1

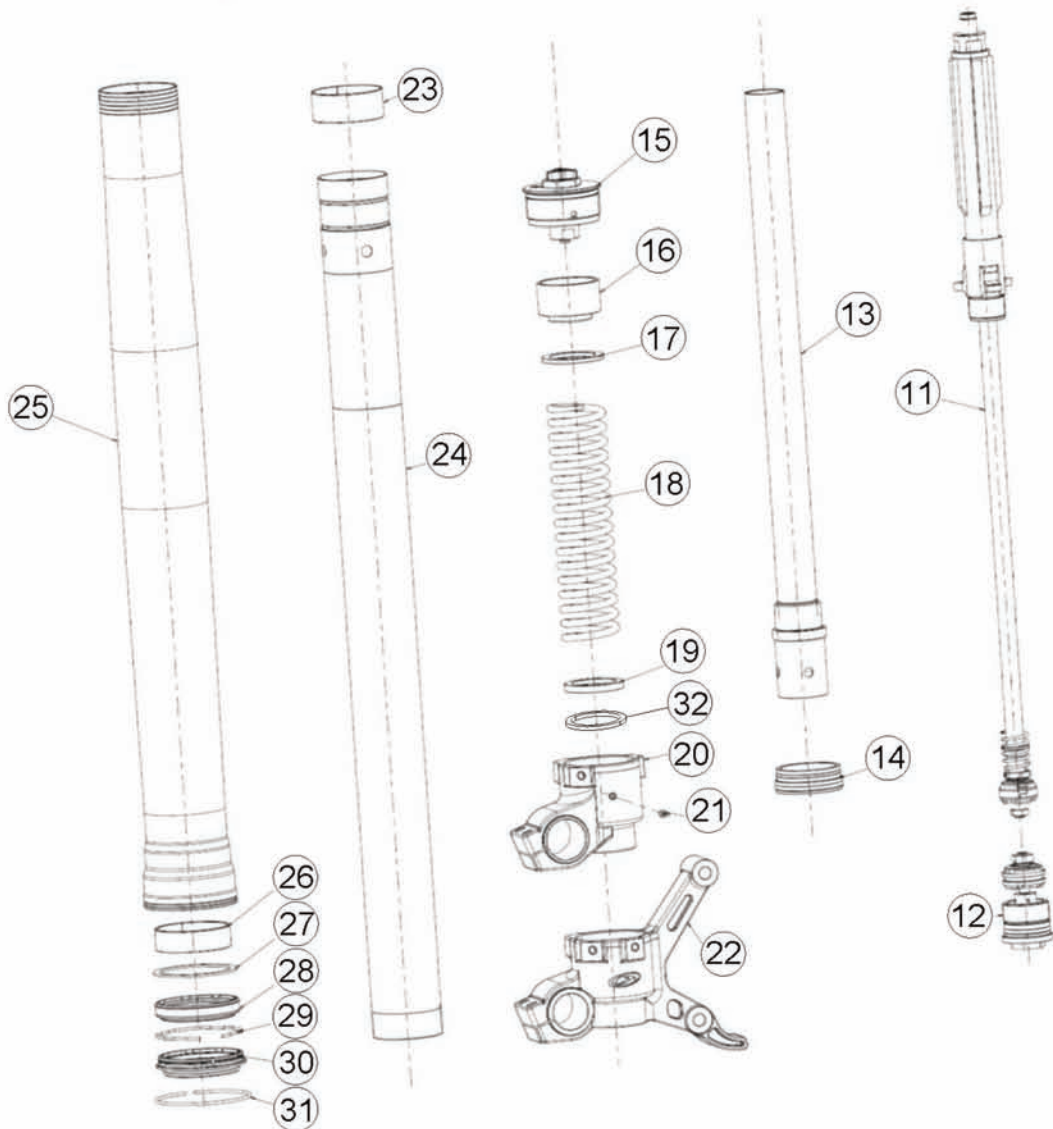

Tav.34

Pos Loc Pos Ps Pos	Numero Number Numé ro Número Nummer	Q.tà Q.ty Q.té M.ge C.ad	Nota Note Note Nota Anm.	Descrizione	Description	Dé signation	Beschreibung	Descrìpziò n
1	026342008 000	1		Forcella completa D.48	Stirrup assy. D.48	Fourchette compl. D.48	Schaltgabel, Kompl. D.48	Horquilla compl. D.48
2	026342208 059	1		Gamba dx.	R.H. leg	Tube D.	Beineinheit R.	Pata der.
3	026342108 059	1		Gamba sx.	L.H. leg	Tube G.	Beineinheit L.	Pata izq.
4	020340040 000	1		Dado 20X1,5	Nut 20X1,5	Ecrou 20X1,5	Mutter 20X1,5	Tuerca 20X1,5
5	1155440 000	1		Bullone 8x30 ch10 rs	Bolt 8x30 ch10 rs	Boulon 8x30 ch10 rs	Bolzen 8x30 ch10 rs	Tornillo 8x30 ch10 rs
6	1155510 000	2		Bullone M8x40	Bolt M8x40	Boulon M8x40	Bolzen M8x40	Tornillo M8x40
7	1066420 000	1		Anello OR 20,22.3,53 NBR	O-Ring 20,22.3,53 NBR	Bague d' é tanché ité 20,22.3,53 NBR	O-Ring 20,22.3,53 NBR	Anillo OR 20,22.3,53 NBR
8	026340020 004	1		Testa di sterzo	Steering head	Tête de direction	Gabelkopf	Tija superior
9	026340018 004	1		Crociera con canotto	Lowe yoke	Croisiere a/tube fourche	Untere Gabelbrücke	Pletina con tubo
10	1155510 000	2		Bullone M8x40	Bolt M8x40	Boulon M8x40	Bolzen M8x40	Tornillo M8x40
11	026343340 000	2		Gruppo pacco distensione	Extension pack assembly	Ensemble paquet extension	Baugruppe zugstufe	Conjunto paquete extensió n
12	026343350 000	2		Gruppo pacco compressione	Compression pack assembly	Ensemble paquet compression	Baugruppe compressionpacket	Conjunto paquete compresió n
13	020343260 000	2		Tubo interno	Inner tube	Tube inté rieur	Gabel Innenrohr	Tubo interior
14	020343130 000	2		Anello appoggio stelo + O-Ring	Stem supporting ring + O-Ring	Anneau appui tige + O-Ring	Anlagering für stange + O-Ring	Anillo de apoyo varilla + O-Ring
15	026343300 000	2		Gruppo tappo	Plug assy	Groupe bouchon	Verschlussgruppe Kpl	Grupo tapó n
16	026343310 000	2		Distanziale in nylon	Nylon spacer	Entretoise en nylon	Nylon-Distanzstück	Separador de nylon
17	031343230 000	2		Rosetta	Washer	Rondelle	Federring	Arandela
18	026343320 000	1		Kit molle	Springs kit	Gr. ressorts	Federset	Kit muelles
19	031343210 000	2		Anello centraggio	Centering ring	Bague de centrage	Zentrierring	Anillo de centrage
20	020343310 000	1		Piedino dx forcella	R.H. fork foot	Pied de fourche droit	Gabelfuß rechts	Pata horquilla der.
21	020343080 000	2		Grano	Dowel	Goujon	Stift	Clavija
22	020343110 000	1		Piedino sx forcella	L.H. fork foot	Pied de fourche gauche	Gabelfuß links	Pata horquilla izq.
23	020343200 000	2		Boccola Ø49/47 L 20	Bush Ø49/47 L 20	Moyeu Ø49/47 L 20	Büchse Ø49/47 L 20	Buje Ø49/47 L 20
24	026343290 000	2		Stelo	Stem	Tige	Stange	Varilla
25	020343280 000	2		Fodero	Sleeve	Protection	Schutzstück	Protecció n
26	020343190 000	2		Boccola Ø52/48 L 15	Bush Ø52/48 L 15	Moyeu Ø52/48 L 15	Büchse Ø52/48 L 15	Buje Ø52/48 L 15
27	020343180 000	1		Distanziale	Spacer	Entretoise	Distanzstück	Distanciador
28	020343170 000	2		Guarnizione	Packing	Joint	Dichtung	Junta
29	020343160 000	2		Seeger Ø58,45	Circlip Ø58,45	Circlip Ø58,45	Seeger Ø58,45	Seeger Ø58,45
30	020343150 000	2		Raschiapolvere	Dust scraper	Graffe poussiere	Staubabstreifer	Esc. polvo
31	020343140 000	2		Seeger Ø64,5 Ø2	Circlip Ø64,5 Ø2	Circlip Ø64,5 Ø2	Seeger Ø64,5 Ø2	Seeger Ø64,5 Ø2
32	026343330 000	2		Disco di centraggio	Centering disk	Disque de centrage	Zentrierring	Disco de centrage

Tav.34A

Versione RACING
RACING version
Version RACING
Version RACING
Version RACING

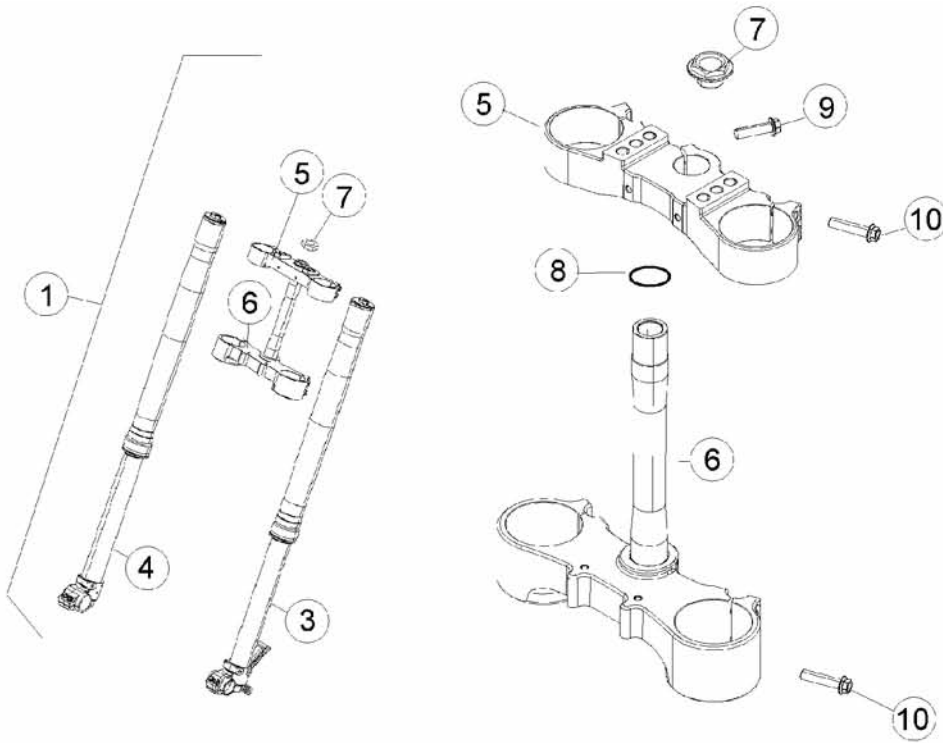



- Olio forcella
- Fork oil
- Gabelöl
- Huile de fourche
- Aceite de horquilla

BETA consiglia:
 BETA recommends:
 BETA empfiehlt:
 BETA recommande:
 BETA recomienda:

SAE 7,5

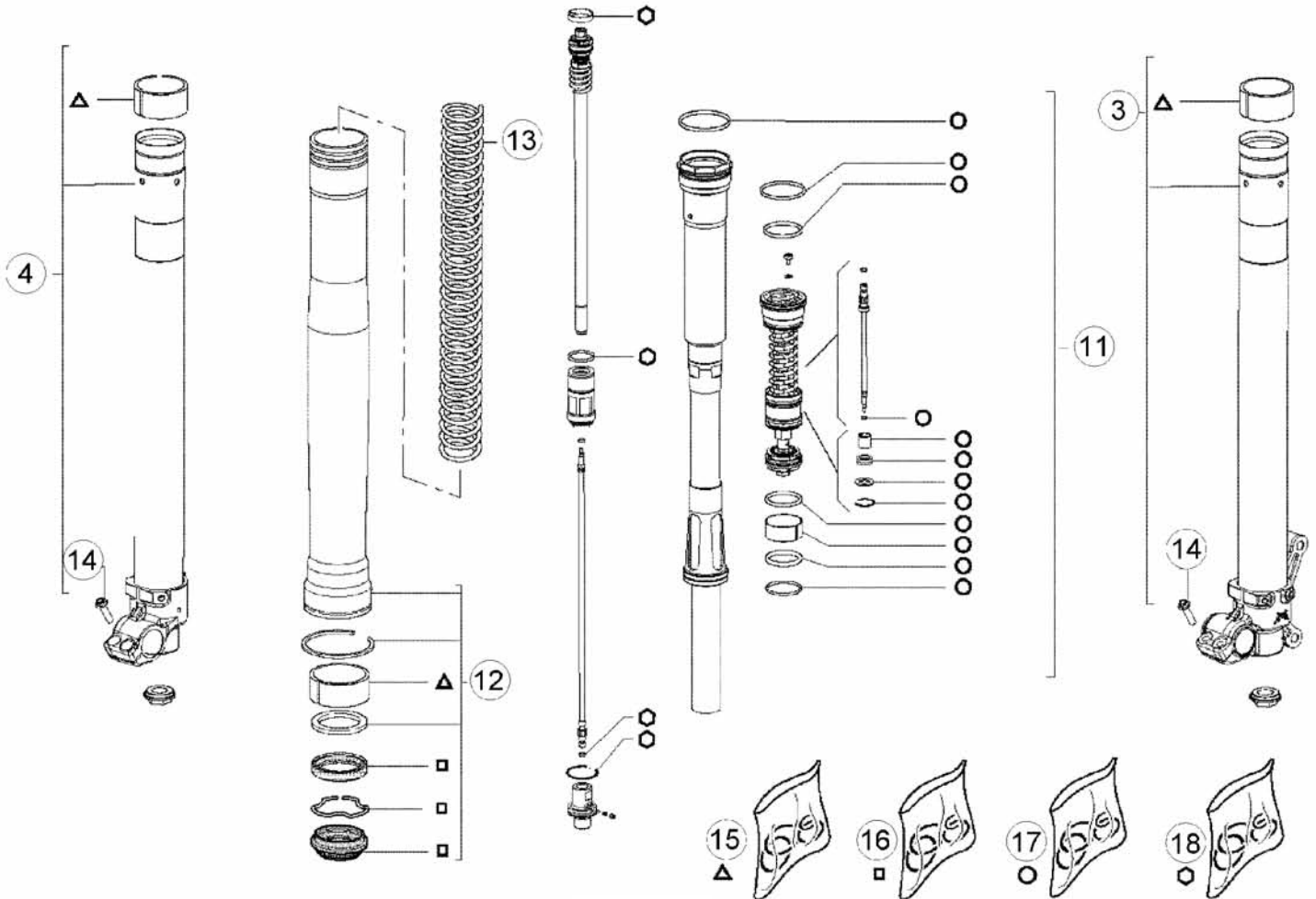

Tav.34A

Pos Loc Pos Ps Pos	Numero Number Numéro Número Nummer	Q.tà Q.ty Q.té M.ge C.ad	Nota Note Note Nota Anm.	Descrizione	Description	Désignation	Beschreibung	Descripcìon
								Versione RACING RACING version Version RACING Version RACING Versión RACING
1	026341008 000	1		Forcella D 48	Fork D 48	Fourche D 48	Gabel D 48	Horquilla D 48
3	026341108 000	1		Gamba sx	LH leg	Tube G.	Linke Beineinheit	Pata izquierda
4	026341208 000	1		Gamba dx	RH leg	Tube D.	Rechte Beineinheit	Pata derecha
5	026340020 059	1		Testata Forcella	Fork head	Tete forche	Obere gabelbrueke	Culata horquilla
6	026340018 059	1		Crociera con cannotto	Lower yoke	Croisiere a/tube fourche	Untere Gabelbrücke	Pletina con tubo
7	020340040 000	1		Dado 20X1,5	Nut 20X1,5	Ecrou 20X1,5	Mutter 20X1,5	Tuerca 20X1,5
8	1066420 000	1		Anello OR 20,22.3,53 NBR	O-Ring 20,22.3,53 NBR	Bague d'é tanché ité 20,22.3,53 NBR	O-Ring 20,22.3,53 NBR	Anillo OR 20,22.3,53 NBR
9	1155440 000	1		Bullone 8x30 ch10 rs	Bolt 8x30 ch10 rs	Boulon 8x30 ch10 rs	Bolzen 8x30 ch10 rs	Tornillo 8x30 ch10 rs
10	1155510 000	8		Bullone M8x40	Bolt M8x40	Boulon M8x40	Bolzen M8x40	Tornillo M8x40
11	031343288 000	1		Cartuccia forcella	Fork spares	Cartouche fourche	Gabeldaempfer	Cartucho horquilla
12	031343298 000	1		Gamba forcella	Right fork	Jante fourche	Gabelbein	Brazo horquilla
13	026343280 000	1		Kit molle K=4,2	Springs kit K=4,2	Gr. ressorts K=4,2	Federset K=4,2	Kit muelles K=4,2
14	3130574 000	4		Vite M5x25	Screw M5x25	Vis M5x25	Schraube M5x25	Tornillo M5x25
15	020345160 000	1		Kit boccole	Bush kit	Kit douille	Buchsekit	Kit manguito
16	031343310 000	1		Kit paraoli	Oil seals kit	Jeu pare-huile	Dichtringsatz	Juego sellos de lub.
17	020345180 000	1		Kit ricambio compressione	Compression kit	Jeu de compression	Kit Kompression	Kit en compresión
18	020345190 000	1		Kit tenuta olio forcelle	Fork oil seal kit	Kit joints d'etanché ité	Dichtungskit	Kit estanqueidad

Tav.35

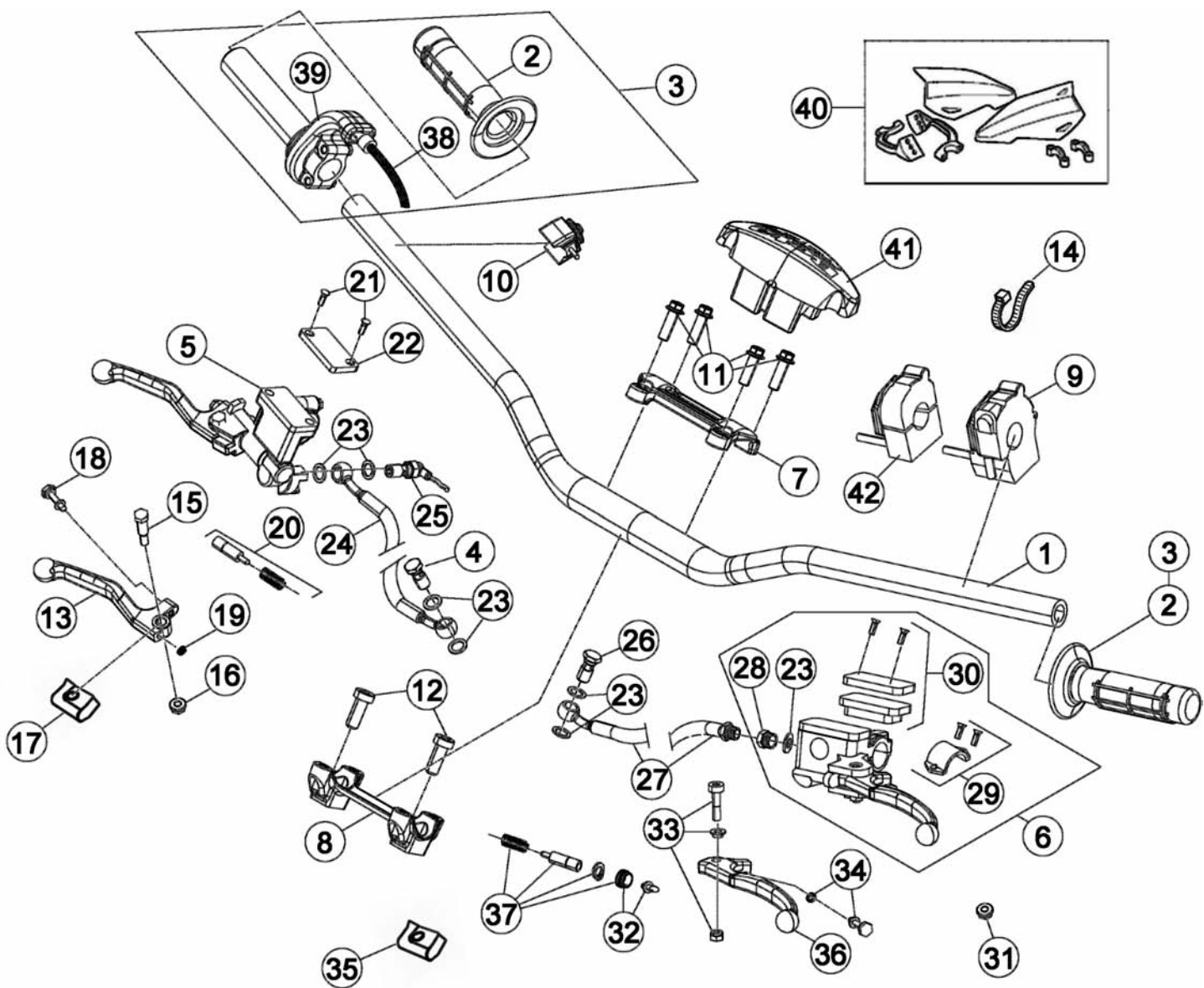

Tav.35

Pos Loc Pos Ps Pos	Numero Number Numéro Número Nummer	Q.tà Q.ty Q.té M.ge C.ad	Nota Note Note Nota Anm.	Descrizione	Description	Dé signation	Beschreibung	Descrìpziò n
1	026350000 059	1		Manubrio	Handlebars	Guidon	Lenker	Manillar
2	2218537 000	1		Coppia manopole	Grips (couple)	Poignées (couple)	Handgriffpaar	Manecilla (juego)
3	026350108 000	1		Comando gas completo	Throttle control compl.	Commande gaz compl.	Gasgriff kpl.	Accionamiento acelerador co
4	1165053 000	1		Bullone forato 10x1,25	Pierced bolt 10x1,25	Boulon avec trou 10x1,25	Bolzen 10x1,25	Tornillo 10x1,25
5	2102057 000	1		Leva freno ant.	Fr. br. lever	Lev. fr. AV.	Vorderradbremshebel	Pal. fr. del.
6	020350200 000	1		Leva comando frizione	Clutch control lever	Levier de commande embrayage	Kupplungshebel	Palanca mando embrague
7	1208253 000	1		Cavallotto superiore	Upper u bolt	Etrier sup.	Obere Brücke	Brida sup.
8	1208263 000	1		Cavallotto inferiore	Lower u bolt	Etrier inférieure	Untere Brücke	Brida inferior
9	1306506 000	1		Commutatore luci	Lights switch	Commutateur feux	Lichtschalter	Conmutador luces
10	1884981 000	1		Interruttore avviamento	Starter switch	Commutateur demarrage	Anlasschalter	Interruptor de arranque
11	3164070 000	4		Vite flangiata 8x30	Flanged screw 8x30	Vis à brides 8x30	Flanschschraube 8x30	Tornillo rebordeado 8x30
12	3165626 000	2		Vite a brugola M10 25	Allen screw M10 25	Vis à 6 pans M10 25	Sechskantschraube M10 25	Tornillo a llave allen M10 25
13	2127104 000	1		Leva freno	Brake lever	Levier du frein	Bremshebel	Palanca de freno
14	1514264 000	3		Fascetta	Clamp	Collier	Schelle	Abrazadera
15	3196832 000	1		Perno leva freno	Brake lever pin	Goujon levier frein	Bremshebelstift	Perno leva freno
16	1330911 000	1		Dado	Nut	Ecrou	Mutter	Tuerca
17	1633841 000	1		Coprileva	Lever cover	Couvre levier	Hebeldeckel	Cubre-palanca
18	3188604 000	1		Vite regol. leva	Adjusting screw	Vis réglage	Einstellschrauben	Tornillo reg.
19	2238704 000	1		Molla registro leva freno ant.	Front brake lever adjust spring	Ressort enregistrement levier	Regelfeder vorderradbremse	Muelle regul. bomba freno
20	2008258 000	1		Pistoncino completo pompa	Piston assy, pump	Piston compl. pompe	Kolben kplt. Pumpe	Piston completo bomba
21	3123402 000	2		Vite fiss. coperchio	Cover sec. screw	Vis de fix. couvercle	Schraube	Tornillo
22	2008259 000	1		Coperchio serbatoio olio	Oil filler cover	Couvercle réservoir huile	Ölverschlußdeckel	Tapa depósito aceite
23	1650510 000	7		Guarnizione 10x15x1 in rame	Gasket 10x15x1 copper	Joint 10x15x1 cuivre	Dichtung 10x15x1 Kupfer	Junta 10.15.1 (cobre)
24	2909108 000	1		Tubo Freno Ant.	Front brake tube	Tuyau du frein AV.	Vordere Bremsleitung	Tubo freno delantero
25	1889621 000	1		Interruttore stop	Stop switch	Interrupteur stop	Stopschalter	Interruptor stop
26	1165040 000	1		Bullone forato 10x1 x tubo freno	Special bolt	Boulon 10x1 x tube frein	Hohlschraube F.Bremse	Tornillo esp. talad.10.1
27	026350010 000	1		Tubo frizione	Clutch tube	Canalisation embrague	Kupplungsrohr	Tubo embrague
28	020350320 000	1		Raccordo	Joint.p.	Raccord	Stutzen	Racor
29	020350250 000	1		Cavallotto	U bolt	Etrier	Brücke	Brida
30	020350230 000	1		Tappo serbatoio pompa	Master cyl. tank plug	Bouchon réservoir maître cylindre	Behälterverschluß Hauptbremszylinder	Tapón depósito bomba freno
31	020350280 000	1		Antiemulsione	Antiemulsion	Antiemulsion	Eulsionswidriger	Antiemulsion
32	020350290 000	1		Puntalino leva pompa	Push piece	Piece de pression	Druckstück	Varilla de presión
33	020350240 000	1		Perno leva	Lever pin	Goujon levier	Hebelstift	Perno palanca
34	020350300 000	1		Guidamolla	Spring guide	Guide ressort	Federführung	Guía resorte
35	020350270 000	1		Gomma protezione leva	Lever protection grommet	Caoutchouc protection levier	Gummi Hebelerschutz	Goma protección palanca
36	020350220 000	1		Leva frizione nuda	Clutch lever, only	Levier d'embrayage nue	Kupplungshebel	Palanca embrague
37	020350260 000	1		Kit pistoncino pompa	Piston kit master cyl.	Kit piston. maître tre cyl.	Kolbensatz hauptbremszylinder	Kit pistón bomba
38	026350110 000	1		Cavo comando gas	Throttle cable transmission	Transmission commande gaz	Bowdenzüg gasgriff	Transmisión mando gas
39	026350100 000	1		Comando gas	Throttle control	Commande gaz	Gasdrehgriff	Mando gas
40	020450158 051	1	RACING	Kit paramani	Hand guards kit	Kit pare-mains	Kit Handschutz	Kit para manos
41	031350010 000	1	RACING	Protezione manubrio	Handlebar protection	Protection guidon	Lenkerschutz	Protección manillar
42	020400450 000	1	RACING	Dispositivo switch mappa CDI	Switch for double map CDI	Selecteur mappe CDI	Mappingschalter CDI	Conmutador para cambiar el mapa del CDI



- Olio freni
- Brake fluid
- Bremsflüssigkeit
- Liquide de frein
- El líquido de frenos

BETA consiglia:
 BETA recommends:
 BETA empfiehlt:
 BETA recommande:
 BETA recomienda:

BRAKE FLUID DOT 4
BRAKE FLUID DOT 5.1

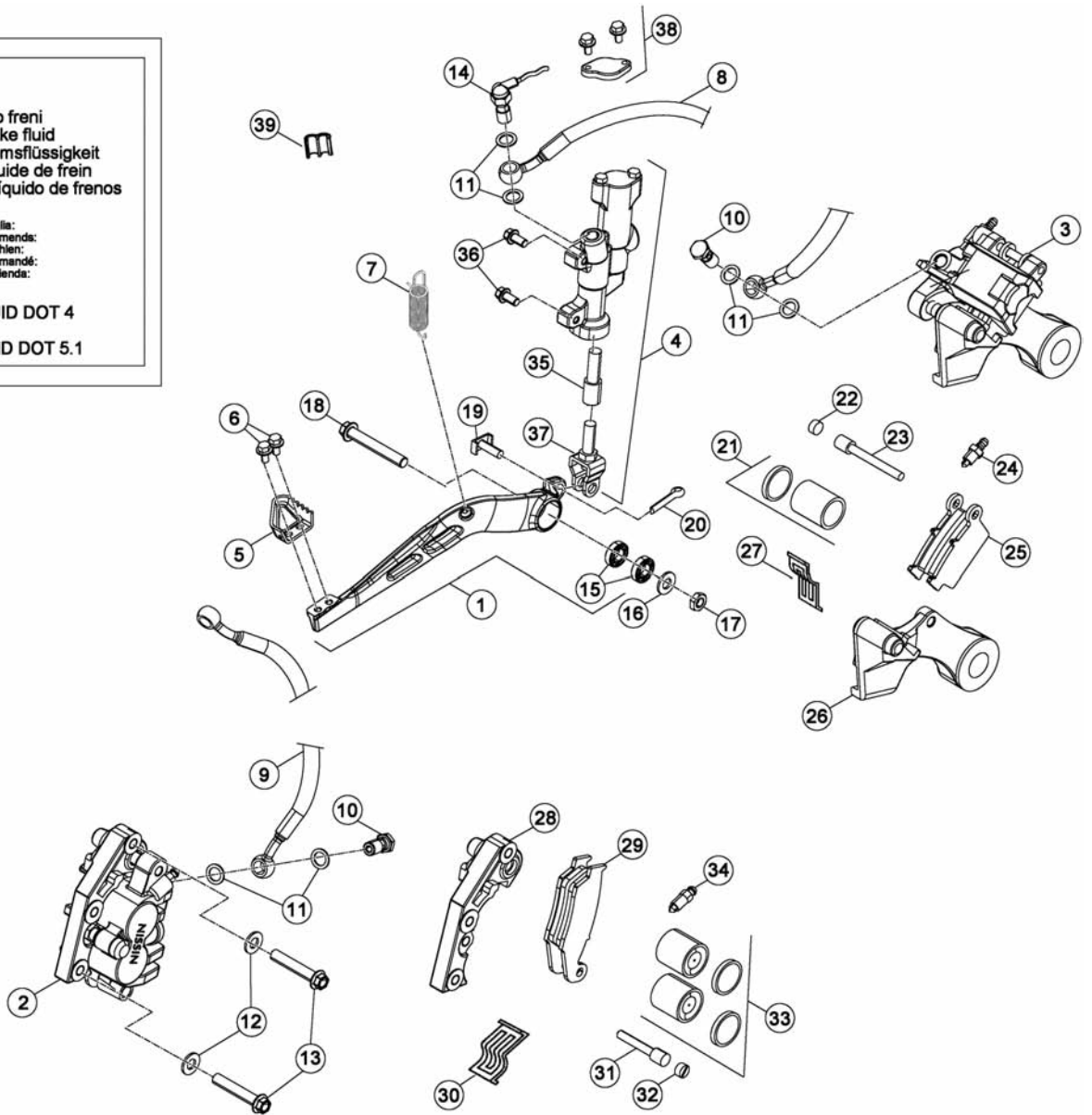

Tav.36

Pos Loc Ps Pos	Numero Number Numéro Número Nummer	Q.tà Q.ty Q.té M.ge C.ad	Nota Note Note Nota Anm.	Descrizione	Description	Dé signation	Beschreibung	Descrìpziò n
1	020360018 000	1		Pedale freno	Brake pedal	Pé dale frein	Fussbremspedal	Pedal freno
1	020360018 059	1	RACING	Pedale freno	Brake pedal	Pé dale frein	Fussbremspedal	Pedal freno
2	2503056 000	1		Pinza freno anteriore	Front disk brake caliper	Etrier de frein AV.	Bremszange-Scheibe	Pinza freno del.
2	020360108 059	1	RACING	Pinza freno anteriore	Front disk brake caliper	Etrier de frein AV.	Bremszange-Scheibe	Pinza freno del.
3	2503066 000	1		Pinza freno posteriore	Rear disk brake caliper	Etrier de frein AR.	Bremszange	Pinza del freno tras.
4	2591178 000	1		Pompa freno posteriore	Rear brake cylinder	Maî tre cylindre frein ar.	Hauptbremszylinder Hinterradbremse	Bomba freno trasero
5	2290053 000	1		Mozzetto	Hub	Moyeu	Nabe	Cubo
6	1146251 000	2		Bullone flangiato M5x12	Head Flanged bolt M5x12	Boulon Bridé M5x12	Bundbolzen M5x12	Bulón con Brida M5x12
7	026360000 000	1		Molla ritorno pedale freno	Return brake pedal spring	Ressort de retour frein	Bremspedal Feder	Muelle retorno palanca freno
8	2909428 000	1		Tube Freno Posteriore	Rear brake tube	Tuyau du frein AR.	Hintere Bremsleitung	Tube freno trasero
9	2909108 000	1		Tube Freno Ant.	Front brake tube	Tuyau du frein AV.	Vordere Bremsleitung	Tube freno delantero
10	1165053 000	2		Bullone forato 10x1,25	Pierced bolt 10x1,25	Boulon avec trou 10x1,25	Bolzen 10x1,25	Tornillo 10x1,25
11	1650510 000	6		Guarnizione 10x15x1 in rame	Gasket 10x15x1 copper	Joint 10x15x1 cuivre	Dichtung 10x15x1 Kupfer	Junta 10.15.1 (cobre)
12	2749500 000	2		Rondella 8x18	Washer 8x18	Rondelle 8x18	U.Scheibe 8x18	Arandela 8x18
13	1155690 000	2		Bullone M8x45 ch10 rs	Bolt M8x45 ch10 rs	Boulon M8x45 ch10 rs	Bolzen M8x45 ch10 rs	Tornillo M8x45 ch10 rs
13	1155470 000	2	RACING	Bullone M8x35	Bolt M8x35	Boulon M8x35	Bolzen M8x35	Tornillo M8x35
14	1889621 000	1		Interruttore stop	Stop switch	Interrupteur stop	Stopschalter	Interruptor stop
15	1293388 000	2		Cuscinetto 8x22x7	Bearing 8x22x7	Roulement 8x22x7	Lager 8x22x7	Cojinete 8x22x7
16	2749500 000	1		Rondella 8x18	Washer 8x18	Rondelle 8x18	U.Scheibe 8x18	Arandela 8x18
17	1317020 000	1		Dado autoblocc. Basso M8	Nut M8	Ecrou M8	Mutter M8	Tuerca M8
18	1155909 000	1		Bullone M8x55	Bolt M8x55	Boulon M8x55	Bolzen M8x55	Tornillo M8x55
19	2541830 000	1		Forcellino	Clip	Ressort	Fixiergabel	Horquilla
20	1281995 000	1		Copiglia 2x15	Split pin 2x15	Goupille 2x15	Splint 2x15	Grupilla 2x15
21	2002717 000	1		Kit pistoncini e guarniz. Pinza	Piston e oil seal for pliers	Jeu petit pistons et joint pinces	Reparatursatz Bremszange	Juego piston y guarnicion pinza
22	3196821 000	1		Grano	Dowel	Goujon	Stift	Clavija
23	2541860 000	1		Perno ancoraggio pastiglia	Pin hanger	Pivot ancrage	Halter brehsbelage	Varilla esp. Pastillas pinzas
24	2891002 000	1		Sfiato	Breather	Reniflard	Entlüfter	Respiradero
25	2525362 000	1		Pastiglie freno post.	Rear brake pads	Pastill. de freins AR.	Hinterbremsbelag	Pastillas frenos tras.
26	020360110 000	1		Staffa supporto pinza	Caliper support bracket	Bride support é trier	Bremssattelbefestigung	Brida soporte pinza
27	2232208 000	1		Molla ferma pastiglie pinza	Brake pads spring for pliers	Ressort arret plaquettes	Haltefeder	Muelle pastillas pinza
28	020360120 000	1		Staffa supporto pinza	Caliper support bracket	Bride support é trier	Bremssattelbefestigung	Brida soporte pinza
28	1096160 000	1	RACING	Staffa supporto pinza	Caliper support bracket	Bride support é trier	Bremssattelbefestigung	Brida soporte pinza
29	2525361 000	1		Pastiglie freno ant.	Front brake pads	Pastill. de freins AV.	Vorderbremsbelag	Pastillas frenos del.
30	2232207 000	1		Molla ferma pastiglie pinza	Brake pads spring for pliers	Ressort arret plaquettes	Haltefeder	Muelle pastillas pinza
31	2541859 000	1		Perno ancoraggio pastiglia	Pin hanger	Pivot ancrage	Halter brehsbelage	Varilla esp. Pastillas pinzas
32	3196821 000	1		Grano	Dowel	Goujon	Stift	Clavija
33	2002716 000	1		Kit pistoncini e guarniz. Pinza	Piston e oil seal for pliers	Jeu petit pistons et joint pinces	Reparatursatz Bremszange	Juego piston y guarnicion pinza
34	2891001 000	1		Sfiato	Breather	Reniflard	Entlüfter	Respiradero
35	2008276 000	1		Kit pistoncino pompa post.	Piston kit rear master cyl.	Kit piston. maî tre cyl. AR.	Kolbensatz hinterhauptbremszylinder	Kit pistón bomba tras.
36	3130750 000	2		Vite M6x16	Screw M6x16	Vis M6x16	Schraube M6x16	Tornillo M6x16
37	2008277 000	2		Kit leva	lever kit	Jeu levier	Hebelsatz	Juego palanca
38	2008275 000	1		Kit serbatoio pompa	Kit, pump tank	Kit reservoir pompe	Deckel pumpstaje	Kit deposito bomba
39	2524442 000	1		Passacavo 6/8	Fair lead 6/8	Passe-fils 6/8	Kabelführung 6/8	Pasa-cable 6/8

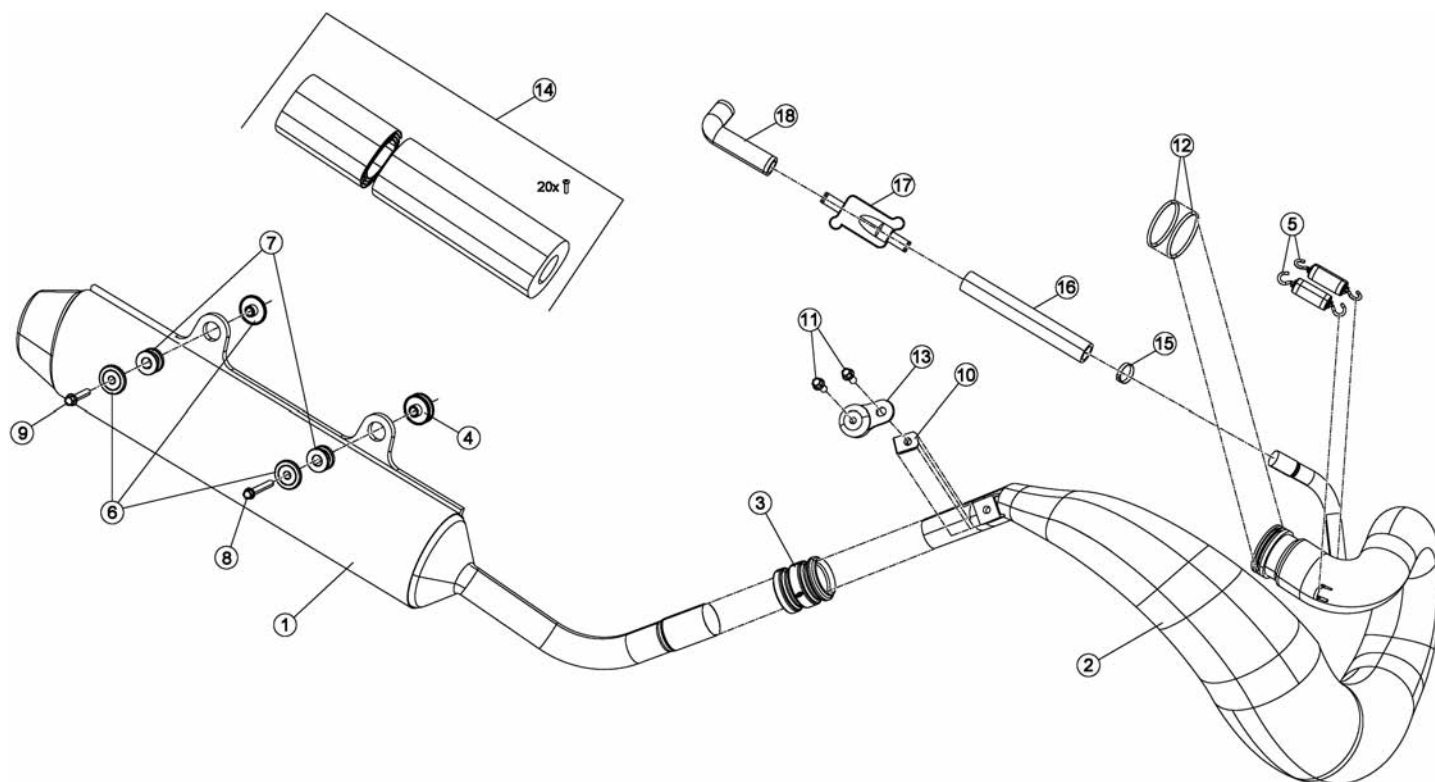

Pos Loc Pos Ps Pos	Numero Number Numéro Número Nummer	Q.tà Q.ty Q.té M.ge C.ad	Nota Note Note Nota Anm.	Descrizione	Description	Dé signation	Beschreibung	Descrisció n
1	026370008 000	1		Silenziatore completo	Silencer complete	Silencieux complet	Endschalldämpfer	Silenciador completo
2	026370018 000	1		Collettore di scarico	Exhaust manifold	Collecteur d' échapp.	Abgaskrü mmer	Colector de escape
3	026370030 000	1		Guarnizione marmitta	Exhaust gasket	Joint pot d' echappement	Dichtung	Goma silenciador
4	026370040 000	1		Distanziale	Spacer	Entretoise	Distanzstück	Distanciador
5	026370050 000	2		Molla tubo di scarico	Exhaust pipe spring	Ressort tuyau echapp.	Krummerfeder	Muelle tubo de escape
6	026370060 000	3		Distanziale	Spacer	Entretoise	Distanzstück	Distanciador
7	2891946 000	2		Silentbloc	Silentbloc	Silentbloc	Puffer	Silent-block
8	1150360 000	1		Bullone M6x40	Bolt M6x40	Boulon M6x40	Bolzen M6x40	Tornillo M6x40
9	1150300 000	1		Bullone 6x30 ch rs	Bolt 6x30 ch rs	Boulon 6x30 ch rs	Bolzen 6x30 ch rs	Tornillo 6x30 ch rs
10	2560311 000	1		Piastrina elastica M6	Spring plate M6	Plaquette é lastique M6	Plättchen M6	Pletina elástica M6
11	1148025 000	2		Bullone M6x16	Bolt M6x16	Boulon M6x16	Bolzen M6x16	Tornillo M6x16
12	C02060510 000	2		Anello OR	O-Ring	Bague d' é tanché ité	O-Ring	Anillo OR
13	2891943 000	1		Silent block marmitta	Silencer puffer	Silent block silencieux	Silent block Auspuff	Silent block escape
14	026370078 200	1		Kit revisione silenziatore	Kit for silencer overhauling	Kit ré v. Silencieux	Reparatursatz Schalldämpfer	Kit revisión silenciador
15	1067470 000	1		Anello stringitubo	Pipe clamping ring	Anneau serre-tube	Schlauchschele	Anillo prensatubo
16	008370800 000	1		Tubo marmitta-Valvola AIS	Pipe Silencer-AIS Valve	Tuyau Silencieux-Soupape AIS	Leitung Auspufftopf-Ventil AIS	Tubo Silenciador-Válvula AIS
17	3115070 000	1		Valvola AIS	AIS Valve	Soupape AIS	Ventil AIS	Válvula AIS
18	2915852 000	1		Tubo filtro-Valvola AIS	Pipe Filter box-AIS Valve	Tuyau Boî tier filtre-Soupape AIS	Leitung Sicherungskasten-Ventil AIS	Tubo caja del filtro-Válvula AIS

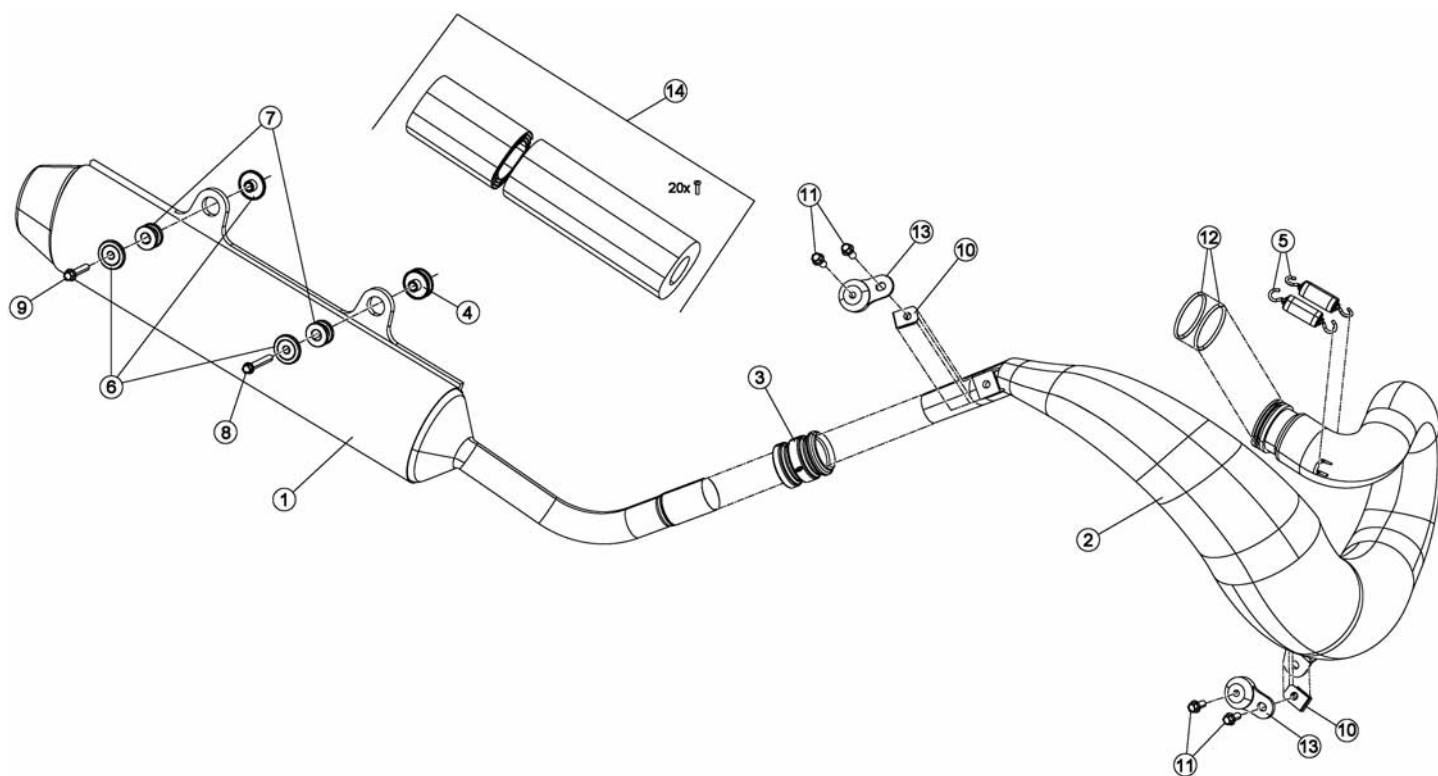

Pos Loc	Numero Number	Q.tà Q.ty	Nota Note	Descrizione	Description	Dé signation	Beschreibung	Descriscìo n
Pos	Numé ro	Q.té	Note					
Ps	Nú mero	M.ge	Nota					
Pos	Nummer	C.ad	Anm.					
1	026370008 000	1		Silenziatore completo	Silencer complete	Silencieux complet	Endschalldä mpfer	Silenciador completo
2	026370028 000	1		Collettore di scarico	Exhaust manifold	Collecteur d' échapp.	Abgaskrü mmer	Colector de escape
3	026370030 000	1		Guarnizione marmitta	Exhaust gasket	Joint pot d' echappement	Dichtung	Goma silenciador
4	026370040 000	1		Distanziale	Spacer	Entretoise	Distanzstü ck	Distanciador
5	026370050 000	2		Molla tubo di scarico	Exhaust pipe spring	Ressort tuyau echapp.	Krummerfeder	Muelle tubo de escape
6	026370060 000	3		Distanziale	Spacer	Entretoise	Distanzstü ck	Distanciador
7	2891946 000	2		Silentbloc	Silentbloc	Silentbloc	Puffer	Silent-block
8	1150360 000	1		Bullone M6x40	Bolt M6x40	Boulon M6x40	Bolzen M6x40	Tornillo M6x40
9	1150300 000	1		Bullone 6x30 ch rs	Bolt 6x30 ch rs	Boulon 6x30 ch rs	Bolzen 6x30 ch rs	Tornillo 6x30 ch rs
10	2560311 000	2		Piastrina elastica M6	Spring plate M6	Plaqueette é lastique M6	Plä ttchen M6	Pletina elä stica M6
11	1147025 000	4		Bullone M6x16	Bolt M6x16	Boulon M6x16	Bolzen M6x16	Tornillo M6x16
12	1066930 000	2		Anello OR	O-Ring	Bague d' é tanché ité	O-Ring	Anillo OR
13	2891943 000	2		Silent block marmitta	Silencer puffer	Silent block silencieux	Silent block Auspuff	Silent block escape
14	026370078 200	1		Kit revisione silenziatore	Kit for silencer overhaling	Kit ré v. Silencieux	Reparatursatz Schalldä mpfer	Kit revisiò n silenciador

Tav.38

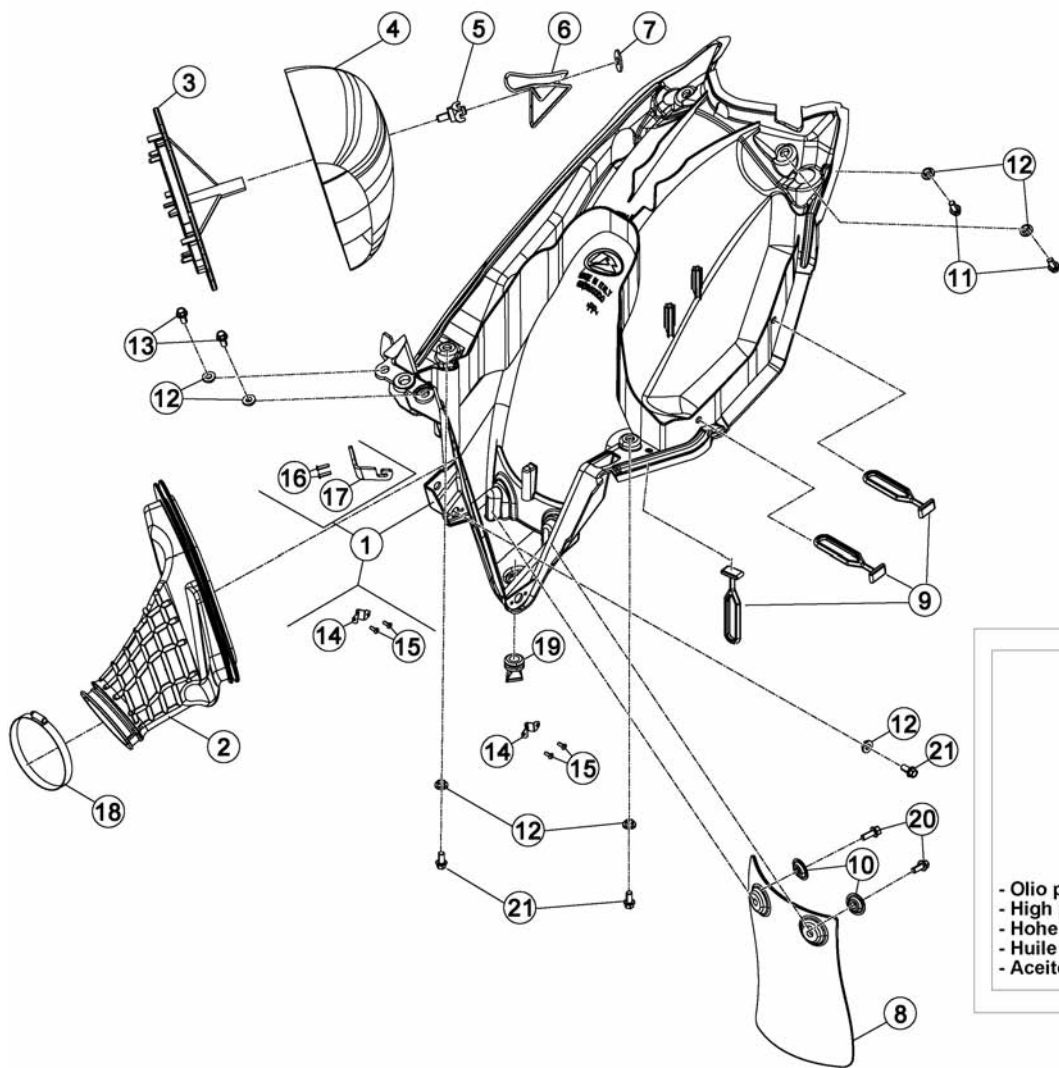

Pos Loc Pos Ps Pos	Numero Number Numéro Número Nummer	Q.tà Q.ty Q.té M.ge C.ad	Nota Note Note Nota Anm.	Descrizione	Description	Désignation	Beschreibung	Descripción
1	031380008 059	1		Scatola filtro completa	Air cleaner box	Boî tier filtre à air	Luftfiltergehäuse	Caja filtro de aire
2	026380010 000	1		Manicotto scatola filtro	Filter box sleeve	Manchon boî te du filtre	Filtergehäuseummuffe	Manguito caja filtro
3	026380020 000	1		Gabbia filtro aria	Filter cage	Grille filtre aire	Filter kafig	Jaula filtro aire
4	031380010 000	1		Filtro aria	Air filter	Filtre à air	Luffilter	Filtro de aire
5	2557197 000	1		Perno richiamo ferma-filtro	Filter pin	Pivot filtre	Filtershalter	Pin Eje filtro
6	020380210 000	1		Molla fermafiltro	Filter spring	Ressort filtre	Filter Feder	Muelle filtro
7	2774800 000	1		Rondella autobloccante 9	Washer 9	Rondelle 9	Scheibe 9	Arandela 9
8	2524416 159	1		Paraspruzzi	Splash guard	Pare-boue	Kotflü gellappen	Gomas aislantes
9	1634907 000	3		Gommino	Rubber buffer	Caoutchouc	Gummi	Goma
10	2774786 000	2		Rondella bombata	Kasher	Rondelle	Scheibe	Arandela
11	3179960 000	2		Vite autofilettante M6x15	Self tapping screw M6x15	Vis taraud M6x15	Schraube, Blech M6x15	Tornillo autorrosc. M6x15
12	1354820 000	7		Distanziale 6,5x9,0x13,5	Spacer 6,5x9,0x13,5	Entretoise 6,5x9,0x13,5	Distanzstück 6,5x9,0x13,5	Distanciadador 6,5x9,0x13,5
13	1147015 000	2		Bullone M6x12	Bolt M6x12	Boulon M6x12	Bolzen M6x12	Tornillo M6x12
14	020380010 000	2		Ricettacolo	Receptacle	Rè ceptacle	Behälter	Receptaculo
15	2733801 000	4		Rivetto a strappo 3x8	Rivet 3x8	Rivet 3x8	Niet 3x8	Remache 3x8
16	2733803 000	2		Rivetto a strappo 3x12	Rivet 3x12	Rivet 3x12	Niet 3x12	Remache 3x12
17	020380020 000	1		Braccetto	Arm	Bras	Kleine Stütze	Brazo
18	1514275 000	1		Fascetta 52/12	Clamp 52/12	Collier 52/12	Schelle 52/12	Abrazadera 52/12
19	1634510 000	1		Tappo in gomma	Rubber cap	Bouchon en caoutchouc	Gummiverschluß	Tapón de goma
20	3130815 000	2		Vite autofilettante 6x20	Self tapping screw 6x20	Vis taraud 6x20	Schraube, Blech 6x20	Tornillo autorrosc. 6x20
21	1148025 000	3		Bullone 6x16 ch 8 rs	Bolt 6x16 ch 8 rs	Boulon 6x16 ch 8 rs	Bolzen 6x16 ch 8 rs	Tornillo 6x16 ch 8 rs



Beta
the play bike

Tav.39

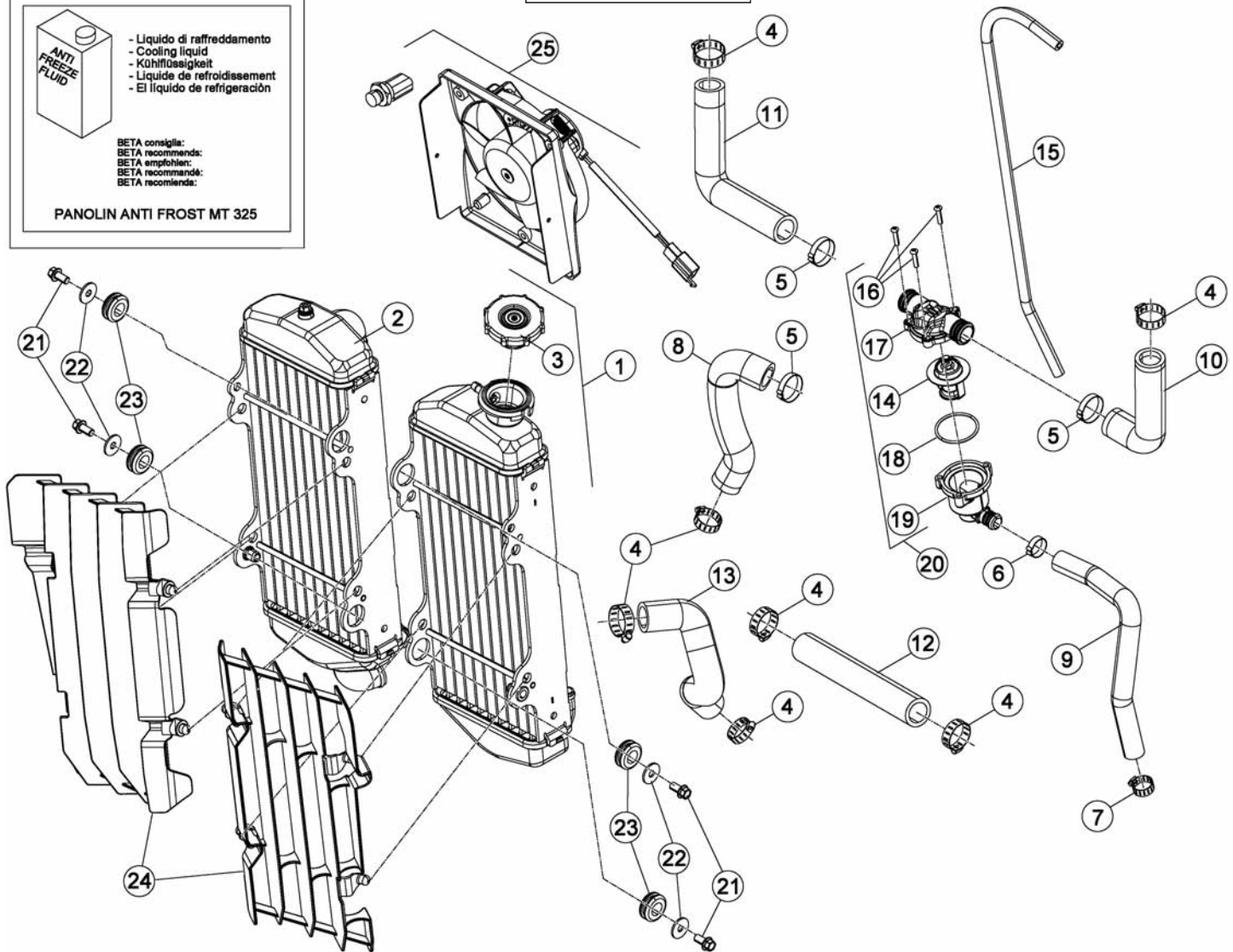

Pos Loc Pos Ps Pos	Numero Number Numéro Número Nummer	Q.tà Q.ty Q.té M.ge C.ad	Nota Note Note Nota Anm.	Descrizione	Description	Désignation	Beschreibung	Descripción
1	026390100 000	1		Radiatore sx	L.H. radiator	Radiateur G.	L., Kühler	Radiador iz.
2	026390000 000	1		Radiatore dx	R.H. radiator	Radiateur D.	R., Kühler	Radiador der.
3	020391110 000	1		Tappo radiatore	Radiator plug	Bouchon radiateur	Kühlerdeckel	Tapa de radiador
4	1515240 000	7		Fascetta 19/28	Clamp 19/28	Collier 19/28	Schelle 19/28	Abrazadera 19/28
5	020390080 000	3		Fascetta 24	Clamp 24	Collier 24	Schelle 24	Abrazadera 24
6	020390090 000	1		Fascetta 17	Clamp 17	Collier 17	Schelle 17	Abrazadera 17
7	1515220 000	1		Fascetta 12/22	Clamp 12/22	Collier 12/22	Schelle 12/22	Abrazadera 12/22
8	026390010 000	1		Tubo termostato-testa	Thermostat-head pipe	Canalisation thermostat-culasse	Leitung Thermostat-Zylinderkopf	Tubo termostato-culata
9	026390020 000	1		Tubo inf. Termostato	Thermostat lower hose	Tube inf. interrupteur thermique	Thermostatschlauch, unten	Tubo inf. Termostato
10	026390030 000	1		Tubo radiatore sx-termostato	L.H. Radiator-Thermostat hose	Tuyau radiateur G.-interr. thermique	Leitung Kühler l.-Thermostatschlauch	Tubo radiador izq.-termostato
11	026390040 000	1		Tubo radiatore dx-termostato	R.H. Radiator-Thermostat hose	Tuyau radiateur D.-interr. thermique	Leitung Kühler r.-Thermostatschlauch	Tubo radiador der.-termostato
12	026390050 000	1		Tubo inferiore radiatori	Lower radiators tube	Tube radiateurs inf.	Wasserschlauch Kühler unten	Tubo radiadores inferior
13	026390060 000	1		Tubo pompa acqua	Water pump pipe	Tube pompe eau	Leitung wasserpumpe	Tubo bomba agua
14	026390130 000	1		Termostato	Bimetal, thermostatic	Thérmostat	Thermostat	Termostato
15	026390070 000	1		Tubo sfianto radiatore	Radiator breather pipe	Tuyau vidange radiateur	Kühlerentlüftungsrohr	Tubo ventilación radiador
16	020390140 000	3		Vite	Screw	Vis	Schraube	Tornillo
17	020390120 000	1		Coperchio termostato	Thermostat cover	Couvercle du thermostat	Thermostatabdeckung	Tapa del termostato
18	02060530 000	1		Anello or 31x2,5	O-Ring 31x2,5	Bague d' é tanché tité 31x2,5	O-Ring 31x2,5	Anillo OR 31x2,5
19	020390110 000	1		Contenitore termostato	Thermostat container	Logement interrupteur thermique	Rahmen Thermostatschlauch	Plástico termostato
20	026390138 000	1		Termostato completo	Thermostat, assy	Thermostat complet	Thermostat komplett	Termostato compl.
21	1147015 000	4		Bullone M6x12	Bolt M6x12	Boulon M6x12	Bolzen M6x12	Tornillo M6x12
22	2743250 000	4		Rondella 6x24	Washer 6x24	Rondelle 6x24	U.Scheibe 6x24	Arandela 6x24
23	1634911 000	4		Gommino	Rubber buffer	Caoutchouc	Gummi	Goma
24	031390030 051	1		Coppia griglie radiatore	Radiator grills	Couples calandres	Kühlergrill	Rejas del radiador
25	026460018 200	1		Kit elettroventola (opzionale)	Electric fan kit (optional)	Jeu electro-ventilateur (Option)	Elektrolüfterbausatz (Optionsbaustein)	Kit electroventilador (opcional)

Tav.40

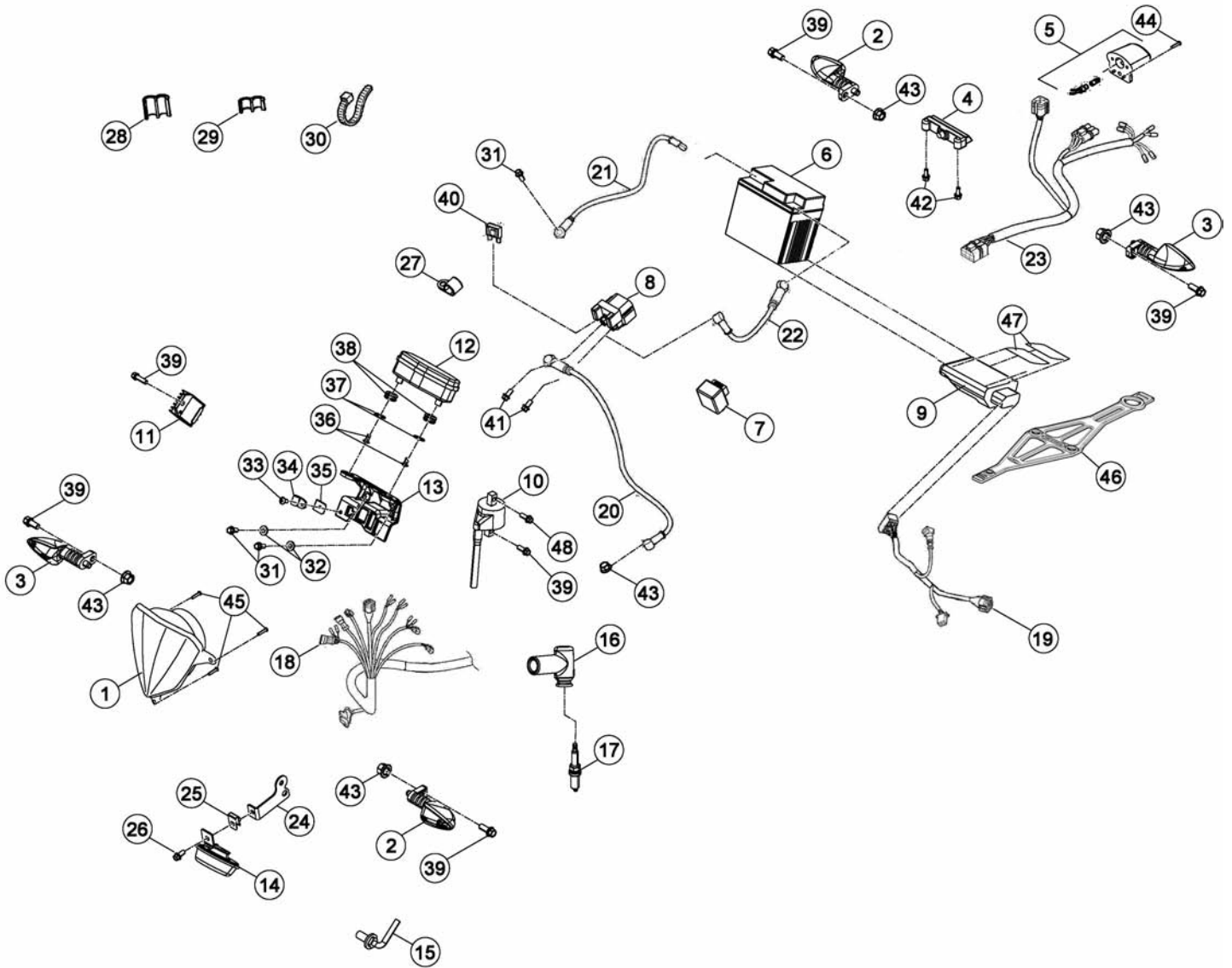

Tav.40

Pos Loc Ps Pos	Numero Number Numéro Nummer	Q.tà Q.ty Q.té M.ge C.ad	Nota Note Nota Anm.	Descrizione	Description	Dé signation	Beschreibung	Descrìpò n
1	1646210 000	1		Faro ant.	Headlamp	Projecteur	Scheinwerfer	Faro del.
2	020400610 000	2		Indicatore dir. ant. sx.-post. Dx	Turn signal L.H.front-R.H.rear	Clignotant av.g.-ar.dr.	Blink. Vorderer links-Hinterer rechts	Indicador del. izq.-tras. der.
3	020400600 000	2		Indicatore dir. ant. dx.-post. Sx	Turn signal R.H.front-L.H.rear	Clignotant av.dr.-ar.g.	Blink.Vorderer rechts-Hinterer links	Indicador del. der.-tras. izq.
4	020400308 000	1		Fanalino posteriore a led	LED tail lamp	Feu AR. à diodes	LED-Rücklicht	Piloto a LED
5	020400200 000	1		Luca Targa	Plate Illumination	Éclairage De Plaque	Kenzeichen-Beleuchtung	Illuminació n Placa
6	1115416 000	1		Batteria	Battery	Batterie	Batterie	Bateria
7	1884948 000	1		Intermittenza	Unit turn signal lamps	Disp. comm. clignot.	Blinkgeber	Disp. intermitentes
8	2728471 000	1		Relais	Relay	Relais	Relay	Relé
9	026400008 300	1	250cc	Centralina digitale 250cc	CDI unit 250cc	Bobine digital (C.D.I.) 250cc	Steuergerät 250cc	Centralita digital 250cc
9	026400008 300	1	250cc	Centralina digitale 250cc	CDI unit 250cc	Bobine digital (C.D.I.) 250cc	Steuergerät 250cc	Centralita digital 250cc
				RACING				
9	026400038 300	1	300cc	Centralina digitale 300cc	CDI unit 300cc	Bobine digital (C.D.I.) 300cc	Steuergerät 300cc	Centralita digital 300cc
9	026400108 300	1	300cc	Centralina digitale 300cc	CDI unit 300cc	Bobine digital (C.D.I.) 300cc	Steuergerät 300cc	Centralita digital 300cc
				RACING				
10	006400108 000	1		Bobina accensione	Ignition coil	Bobine allumage	Zuendspule	Bobina de encendido
11	2728101 000	1		Regolatore	Regulator	Régulateur	Regler	Regulador
12	020408100 050	1		Strumento digitale	Digital instrument	Instrument numérique	Digitalinstrument	Instrumento digital
13	031400110 000	1		Supporto strumento	Instrument holder	Support instruments	Instrumentenhalter	Soporte instrumentos
14	007400500 000	1		Avvisatore acustico	Warning horn	Avertisseur sonore	Hupe	Claxon
15	2879013 000	1		Sensore REED	REED sensor	Sensor REED	Sensor	Sensor REED
16	2713514 000	1		Raccordo candela	Plug fitting	Raccord bougie	Kerzenanschluß	Racor bují a
17	1225220 000	1		Candela	Spark.plug	Bougie	Zundkerze	Bujía
18	020404000 000	1		Impianto centrale	Electric equipment	Installation centrale	Zentraler Kabelbaum	Instalacion central
19	026400070 000	1		Gruppo cavetti centralina iniezione	Injection power unit harness	Groupe fils centrale injection	Kabeleinheit Steuergerät	Conjunto cables centralita de
							Einspritzung	inyecció n
20	026400060 000	1		Cavetto relè avviamento	Starter relay cable	Câ ble relais de demarrage	Anlassrelaiskabel	Cable relé de arranque
21	020400020 000	1		Cavetto di massa	Ground cable	Cable masse	Masse kabel	Cable masa
22	020400030 000	1		Cavo batteria-relè	Battery-Relay cable	Cable batterie-relais	Kabel Batterie-Relais	Cable Baterí a-Relé
23	020401010 000	1		Impianto posteriore	Rear harness	Circuit post.	Anlage hinten	Instalació n tras.
24	2897255 000	1		Staffa supporto claxon	Horn support bracket	Bride support avertisseur	Hupebefestigung	Brida soporte claxon
25	2560311 000	1		Piastrina elastica M6	Spring plate M6	Plaquette é lastique M6	Plättchen M6	Pletina elástica M6
26	1147015 000	3		Bullone M6x12	Bolt M6x12	Boulon M6x12	Bolzen M6x12	Tornillo M6x12
27	1514654 000	1		Fascetta	Clamp	Collier	Schelle	Abrazadera
28	2524442 000	3		Passacavo 6/8	Fair lead 6/8	Passe-fils 6/8	Kabelführung 6/8	Pasa-cable 6/8
29	2524443 000	3		Passacavo 6/6	Fair lead 6/6	Passe-fils 6/6	Kabelführung 6/6	Pasa-cable 6/6
30	1514264 000	4		Fascetta	Clamp	Collier	Schelle	Abrazadera
31	1147015 000	1		Vite M6x12	Screw M6x12	Vis M6x12	Schraube M6x12	Tornillo M6x12
32	1354820 000	2		Distanziale 6,5x9,0x13,5	Spacer 6,5x9,0x13,5	Entretoise 6,5x9,0x13,5	Distanzstück 6,5x9,0x13,5	Distanciadór 6,5x9,0x13,5
33	3123530 000	1		Vite M4,2x16 TMTIC	Screw M4,2x16 TMTIC	Vis M4,2x16 TMTIC	Schraube M4,2x16 TMTIC	Tornillo M4,2x16 TMTIC
34	2525182 000	1		Passacavo	Grommet	Passe-câ ble	Kabeldurchgang	Pasacables
35	2558090 000	1		Piastrina elastica	Spring plate	Plaquette é lastique	Plättchen	Pletina elástica
36	3126190 000	2		Vite M4x12 TCIC	Screw M4x12 TCIC	Vis M4x12 TCIC	Schraube M4x12 TCIC	Tornillo M4x12 TCIC
37	020408120 000	2		Distanziale 5x15	Spacer 5x15	Entretoise 5x15	Distanzstück 5x15	Distanciadór 5x15
38	031400130 000	2		Gommino	Rubber buffer	Caoutchouc	Gummi	Goma
39	1148025 000	6		Bullone 6x16 ch 8 rs	Bolt 6x16 ch 8 rs	Boulon 6x16 ch 8 rs	Bolzen 6x16 ch 8 rs	Tornillo 6x16 ch 8 rs
40	020400060 000	2		Fusibile 10A	Fuse 10A	Fusible 10A	Sicherung 10A	Fusible 10A
41	3130190 000	2		Vite a brugola 6x8	Allen screw 6x8	Vis à 6 pans 6x8	Sechskantschraube 6x8	Tornillo a llave allen 6x8
42	1146251 000	2		Bullone flangiato M5x12	Head Flanged bolt M5x12	Boulon Bridé M5x12	Bundbolzen M5x12	Bulón con Brida M5x12
43	1312550 000	5		Dado flangiato M6	Flanged nut M6	Ecrou bordé M6	Flanschmutter M6	Tuerca embreadada M6
44	3123565 000	1		Vite 4,5x15 TCCCR	Screw 4,5x15 TCCCR	Vis 4,5x15 TCCCR	Schraube 4,5x15 TCCCR	Tornillo 4,5x15 TCCCR
45	3126190 000	3		Vite M4x12 TCIC	Screw M4x12 TCIC	Vis M4x12 TCIC	Schraube M4x12 TCIC	Tornillo M4x12 TCIC
46	026400090 000	1		Elastico fissaggio	Elastic rubber	Elastique de fixation	Befestigungsband	Elastico
47	2910317 000	2		Tampone	Buffer	Silentbloc	Puffer	Silent-block
48	1149070 000	6		Bullone 6x20	Bolt 6x20	Boulon 6x20	Bolzen 6x20	Tornillo 6x20

Tav.41

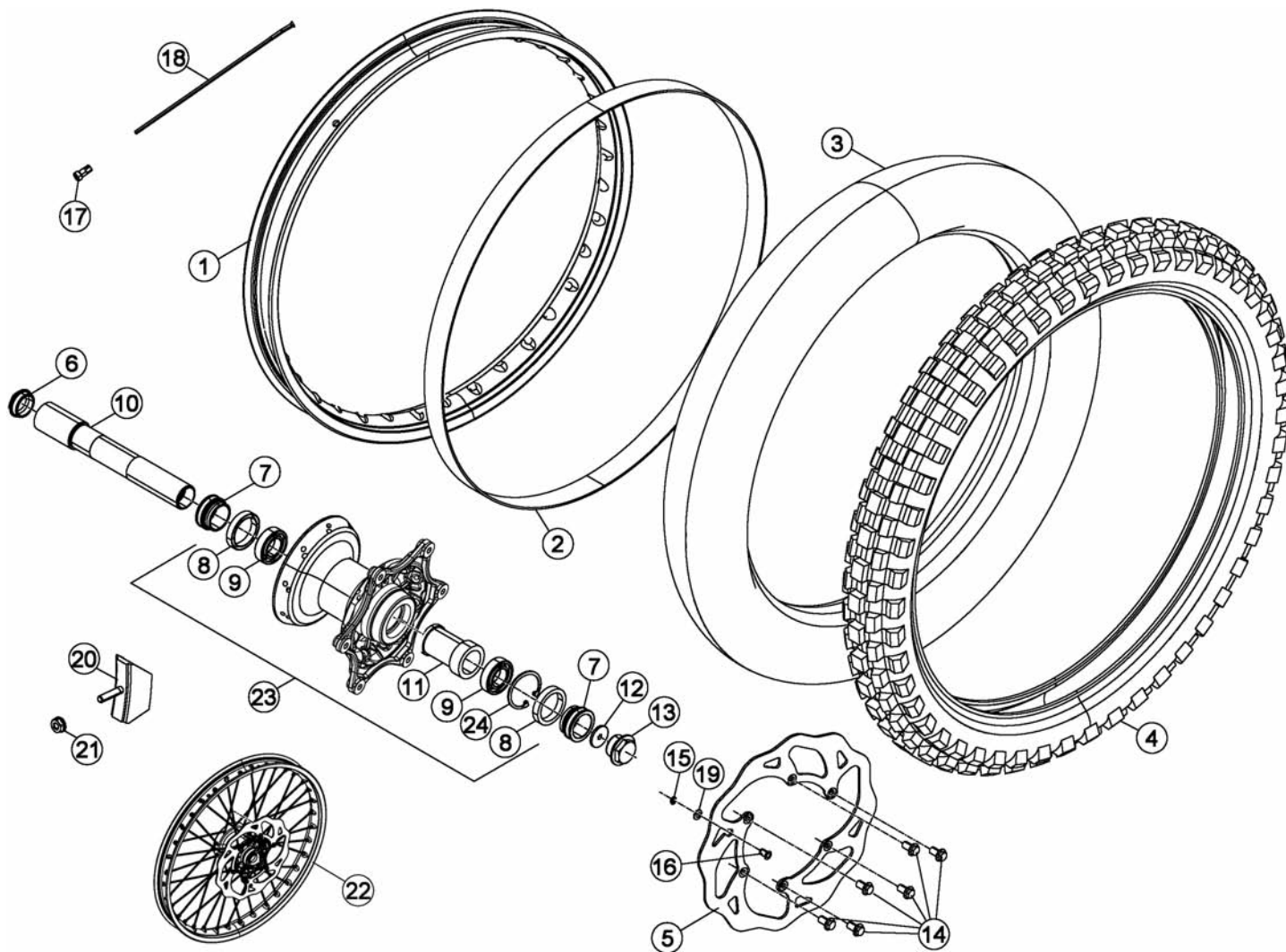

Pos	Numero	Q.tà	Nota	Descrizione	Description	Désignation	Beschreibung	Descripción
Loc	Number	Q.ty	Note					
Pos	Numéro	Q.té	Note					
Ps	Número	M.ge	Nota					
Pos	Nummer	C.ad	Anm.					
1	020411400 059	1		Cerchio anteriore 21x1,6	Front rim 21x1,6	Jante avant 21x1,6	Vorderfelge 21x1,6	Llanta delantera 21x1,6
2	1538200 000	1		Flap 21x25	Bead 21x25	Flap21x25	Felgenband 21x25	Flap cinta tapa radios 21.25
3	1216110 000	1		Camera 2.50-21/2.75-21	Tube 2,50x21-2,75x21	Tube 2,50x21-2,75x21	Schlauch 2,50x21-2,75x21	Camara 2,50x21-2,75x21
4	1281575 000	1		Pneumatico	Tyre	Pneu	Reifen	Neumático
5	031410300 000	1		Disco freno	Brake plate	Disque frein	Bremscheibe	Disco freno
6	020410070 000	1		Tappo perno ruota anteriore	Front wheel pin plug	Bouchon pivot roue avant	Stopfen Pin Vorrad	Tapon eje rueda anterior
6	020410200 053	1	RACING	Tappo perno ruota anteriore	Front wheel pin plug	Bouchon pivot roue avant	Stopfen Pin Vorrad	Tapon eje rueda anterior
7	031410040 000	2		Distanziale ant.	Front spacer	Entretoise AV.	Distanzstück vorderer	Distanciadador del.
8	1066000 000	2		Paraolio 35x47x7	Oil seal 35x47x7	Pare-huile 35x47x7	Dichtring 35x47x7	Sello de lub. 35x47x7
9	020410030 000	2		Cuscinetto 30x47x9	Bearing 30x47x9	Roulement 30x47x9	Lager 30x47x9	Cajinete 30x47x9
10	020410050 000	1		Perno ruota anteriore	Front wheel spindle	Pivot roue AV.	Vorderradzapfen	Perno rueda delantera
11	031410150 000	1		Distanziale interno	Inner spacer	Entretoise interne	Inneres Distanzstück	Distanciadador interior
12	020411100 000	1		Vite speciale	Special screw	Vis spéciale	Spezialschraube	Tornillo especial
13	020410060 000	1		Tappo filettato	Threaded plug	Bouchon fileté	Gewindepropf	Tapón filete
14	031410160 000	6		Vite TEF M6x14	Screw TEF M6x14	Vis TEF M6x14	Schraube TEF M6x14	Tornillo TEF M6x14
15	2822570 000	1		Seeger RA5	Circlip RA5	Circlip RA5	Seeger RA5	Seeger RA5
16	021410050 000	1		Sensore	Sensor	Capteur	Sensor	Sensor
17	031410420 000	36		Nipplo	Nipple	Ecrou	Nippel	Tuerca
18	031410410 000	36		Raggio	Spoke	Rayon	Speiche	Radio
19	2758080 000	1		Rondella spess. 9x13x0,4	Washer 9x13x0,4	Rondelle epaisseur 9x13x0,4	Scheibe 9x13x0,4	Arandela 9x13x0,4
20	1517551 000	1		Fermafascione	Tyre retainer	Arrêt	Felgenhalterung	Sujeta cobertura
21	1317120 000	1		Dado M8 flangiato	Nut M8	Ecrou M8	Mutter M8	Tuerca M8
22	031410000 059	1		Ruota anteriore	Fr.wheel	Roue AV.	Vorderrad	Rueda delantera
23	031410148 000	1		Mozzo anteriore c/cuscineti	Front hub with ballbearing	Moyeu avant avec roulements	Nabe vo.	Buje ant.c/cojinetes
24	C01260010 000	1		Seeger 47x1,75	Circlip 47x1,75	Circlip 47x1,75	Seeger 47x1,75	Seeger 47x1,75



Beta
the play bike

Tav.42

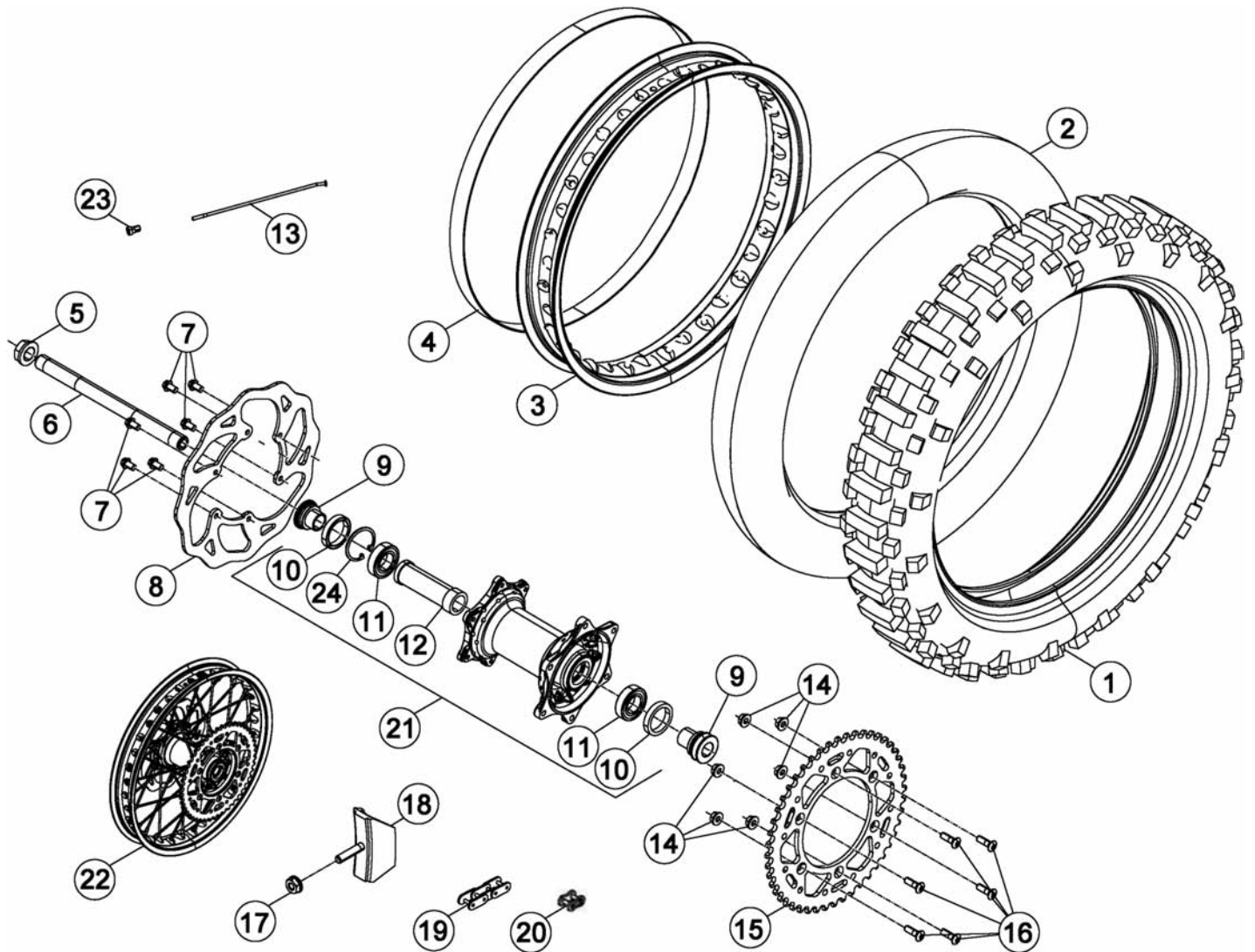

Pos Loc Pos Ps Pos	Numero Number Numéro Número Nummer	Q.tà Q.ty Q.té M.ge C.ad	Nota Note Note Nota Anm.	Descrizione	Description	Désignation	Beschreibung	Descrìption
1	1281584 000	1		Pneumatico	Tyre	Pneu	Reifen	Neumático
2	1218320 000	1		Camera MD-18	Tube MD-18	Tube MD-18	Schlauch MD-18	Camara MD-18
3	020421400 059	1		Cerchio ruota posteriore 18x2,15	Rear wheel rim 18x2,15	Janta roue AR. 18x2,15	Hinterradfelge 18x2,15	Llanta rueda trasera 18x2,15
4	1536000 000	1		Flap 17/18x25	Bead 17/18x25	Flap 17/18x25	Felgenband 17/18x25	Flap cinta tapa radios 17/18x25
5	1327120 000	1		Dado speciale	Special nut	Ecrou spéciale	Spezialmutter	Tuerca especial
6	2555812 000	1		Perno ruota posteriore	Rear wheel pin	Pivot roue arrière re	Hinterradbolzen	Perno rueda trasera
7	031410160 000	6		Vite TEF M6x14	Screw TEF M6x14	Vis TEF M6x14	Schraube TEF M6x14	Tornillo TEF M6x14
8	031420300 000	1		Disco freno posteriore	Rear brake disk	Disque frein arrière re	Hinterbremscheibe	Disco freno trasero
9	031420020 000	2		Distanziale mozzo post. Dx	RH rear hub spacer	Entretoise moyeu arrière D.	Distanz li	Distanciadore buje tras. Der.
10	1066000 000	2		Paraolio 35x47x7	Oil seal 35x47x7	Pare-huile 35x47x7	Dichtring 35x47x7	Sello de lub. 35x47x7
11	020420040 000	2		Cuscinetto 25x47x12	Bearing 25x47x12	Roulement 25x47x12	Lager 25x47x12	Cojinete 25x47x12
12	031420050 000	1		Distanziale interno	Inner spacer	Entretoise interne	Inneres Distanzstück	Distanciadore interior
13	031420410 000	36		Raggio ruota posteriore	Rear wheel spokes	Rayons roue AR.	Hinterradspenken	Radios rueda trasera
14	1317123 000	6		Dado TECF M8	Nut TECF M8	Ecrou TECF M8	Mutter TECF M8	Tuerca TECF M8
15	026420010 000	1		Corona Z49	Ring gear Z49	Couronne Z49	Zahnkranz Z49	Corona Z49
16	3196827 000	6		Vite speciale M8X26	Special screw M8X26	Vis spéciale M8X26	Spezialschraube M8X26	Tornillo especial M8X26
17	1317120 000	1		Dado M8 flangiato	Nut M8	Ecrou M8	Mutter M8	Tuerca M8
18	1517531 000	1		Fermafascioni	Tire fastener	Caoutchouc serrure chambre	Reifen Halter	Agarre cubierta ant.
19	031420030 000	1		Catena P114	Chain P114	Châi ne P114	Kette P114	Cadena P114
20	031420080 000	1		Maglia congiunzione 5/8x1/4	Connecting link 5/8x1/4	Maillon jonction 5/8x1/4	Kettenschloss 5/8x1/4	Eganche cadena 5/8x1/4
21	031420148 000	1		Mozzo posteriore c/cuscinetti	Rear hub with ballbearing	Moyeu arrière avec roulements	Hinterrad Nabe	Buje del. c/cojinetes
22	026420000 059	1		Ruota posteriore p/montata	Front wheel ass.	Roue arrière p/monte'	Vormontiertes hinterrad	Rueda trasera montada
23	031420420 000	36		Nipplo	Nipple	Ecrou	Nippel	Tuerca
24	C01260010 000	1		Seeger 47x1,75	Circlip 47x1,75	Circlip 47x1,75	Seeger 47x1,75	Seeger 47x1,75

Tav.43A

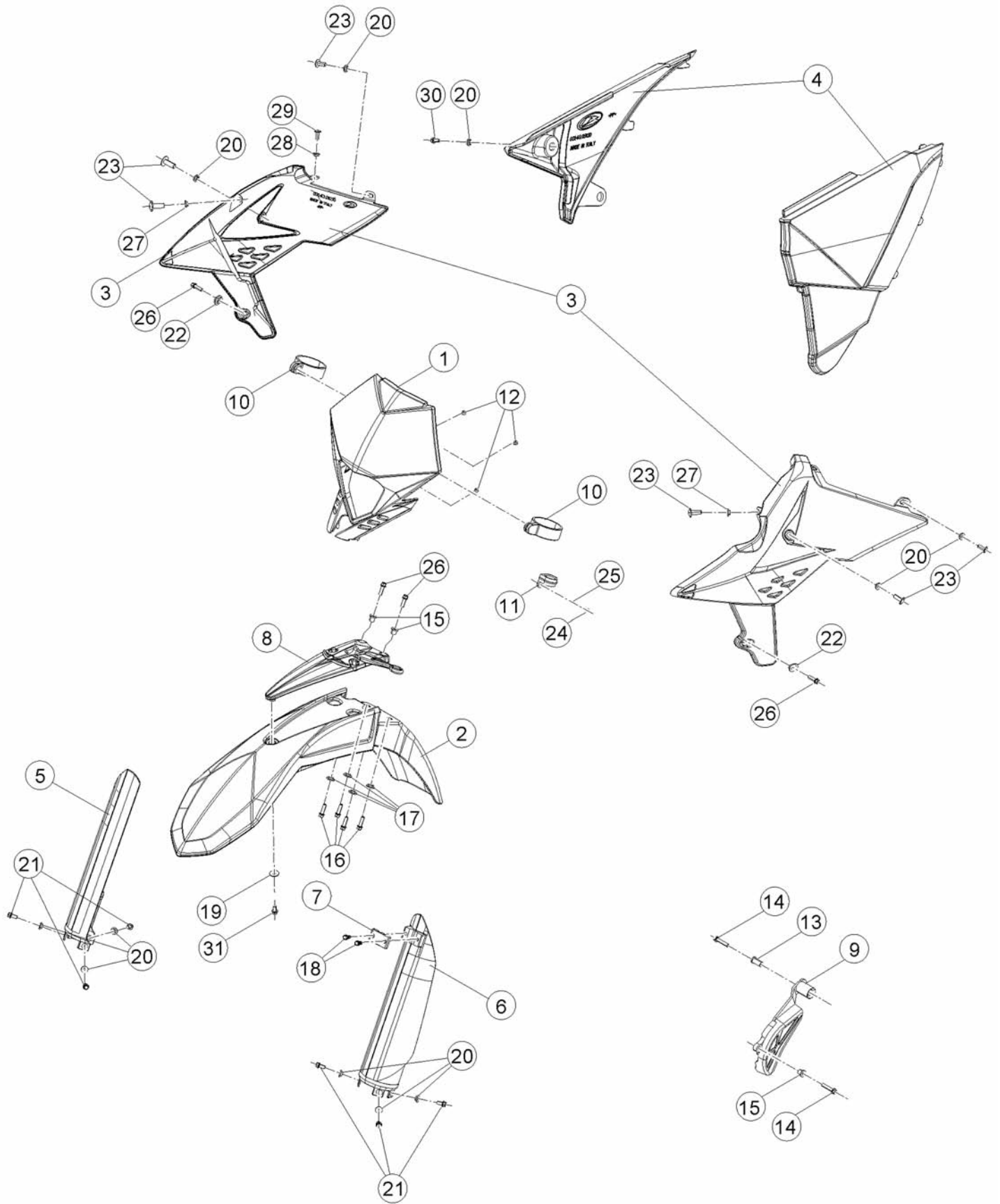

Beta
the play bike

Tav.43A

Pos Loc Pos Ps Pos	Numero Number Numéro Número Nummer	Q.tà Q.ty Q.té M.ge C.ad	Nota Note Note Nota Anm.	Descrizione	Description	Dé signation	Beschreibung	Descrìpziò n
1	020431501 051	1		Mascherina	Mask	Masque	Maske	Mà scara
2	031430341 097	1		Parafango	Mudguard	Garde-boue	Kotflü gel	Guardabarros
3	031430120 097	1		Fianchetti serbatoio	Tank panels	Panneaux laterales	Benzintankseiten	Flancos
4	031430330 051	1		Fianchetti scatola filtro	Airbox panels	Cote lateral boî tier filtre à air	Lufffiltergehä useseiten	Flanco derecho caja filtro aire
5	016340101 051	1		Protezione tubo forcella dx	RH fork tube protection	Protection tube fourche droit	Abdeckung Gabelschlauch re.	Protección tubo horquilla derecho
6	016340111 051	1		Protezione tubo forcella sx	LH fork tube protection	Protection tube fourche gauche	Abdeckung Gabelschlauch li.	Protección tubo horquilla izquierdo
7	2591330 151	1		Ponticello tubo freno	Brake pipe sprocket	Etrier tube frein	Bü gel Bremsschlauch	Abrazadera tubo freno
8	020431411 059	1		Supporto parafango	Fender stay	Appui aile	Kotflü gelstuetze	Soporte de guardabarros
9	020430621 059	1		Coperchio pignone	Sprocket cover	Couvercle pignon	Deckel Ritzel	Tapa piñ ó n
10	1440081 000	2		Elastico fissaggio mascherina	Headlight holder elastic rubber	Elastique de fixation cache phare	Befestigungsband Lichtschildchen	Elastico
11	2524464 000	1		Passacavo	Grommet	Passe-câ ble	Kabeldurchgang	Pasacables
12	3126190 000	3		Vite M4x12 TCIC	Screw M4x12 TCIC	Vis M4x12 TCIC	Schraube M4x12 TCIC	Tornillo M4x12 TCIC
13	1349189 000	1		Distanziale	Spacer	Entretoise	Distanzstü ck	Distanciador
14	1150300 000	2		Bullone 6x30 ch rs	Bolt 6x30 ch rs	Boulon 6x30 ch rs	Bolzen 6x30 ch rs	Tornillo 6x30 ch rs
15	1349190 000	2		Distanziale 10mm	Spacer 10mm	Entretoise 10mm	Distanzstü ck 10mm	Distanciador 10mm
16	1148025 000	4		Bullone 6x16 ch 8 rs	Bolt 6x16 ch 8 rs	Boulon 6x16 ch 8 rs	Bolzen 6x16 ch 8 rs	Tornillo 6x16 ch 8 rs
17	1354841 000	4		Distanziale	Spacer	Entretoise	Distanzstü ck	Distanciador
18	3179960 000	2		Vite autofilettante M6x15	Self tapping screw M6x15	Vis taraud M6x15	Schraube, Blech M6x15	Tornillo autorrosc. M6x15
19	2774786 000	1		Rondella	Washer	Rondelle	U.Scheibe	Arandela
20	1354820 000	11		Distanziale 6,5x9,0x13,5	Spacer 6,5x9,0x13,5	Entretoise 6,5x9,0x13,5	Distanzstü ck 6,5x9,0x13,5	Distanciador 6,5x9,0x13,5
21	1147015 000	6		Bullone M6x12	Bolt M6x12	Boulon M6x12	Bolzen M6x12	Tornillo M6x12
22	020430120 000	2		Distanziale	Spacer	Entretoise	Distanzstü ck	Distanciador
23	3195510 000	6		Vite TBCE M6x12	Screw TBCE M6x12	Vis TBCE M6x12	Schraube TBCE M6x12	Tornillo TBCE M6x12
24	3123360 000	1		Vite autofilettante 4x10	Self tapping screw 4x10	Vis taraud 4x10	Schraube, Blech 4x10	Tornillo autorrosc. 4x10
25	2734650 000	1		Rondella	Washer	Rondelle	U.Scheibe	Arandela
26	1149070 000	4		Bullone 6x20 ch rs	Bolt 6x20 ch rs	Boulon 6x20 ch rs	Bolzen 6x20 ch rs	Tornillo 6x20 ch rs
27	1354828 000	2		Distanziale	Spacer	Entretoise	Distanzstü ck	Distanciador
28	1362000 000	1		Distanziale	Spacer	Entretoise	Distanzstü ck	Distanciador
29	3130035 000	1		Bullone M6x25 TBCEI	Bolt M6x25 TBCEI	Boulon M6x25 TBCEI	Bolzen M6x25 TBCEI	Tornillo M6x25 TBCEI
30	1148025 000	1		Bullone 6x16 ch 8 rs	Bolt 6x16 ch 8 rs	Boulon 6x16 ch 8 rs	Bolzen 6x16 ch 8 rs	Tornillo 6x16 ch 8 rs
31	1146501 000	1		Bullone M6x10	Bolt M6x10	Boulon M6x10	Bolzen M6x10	Tornillo M6x10

Tav.43B

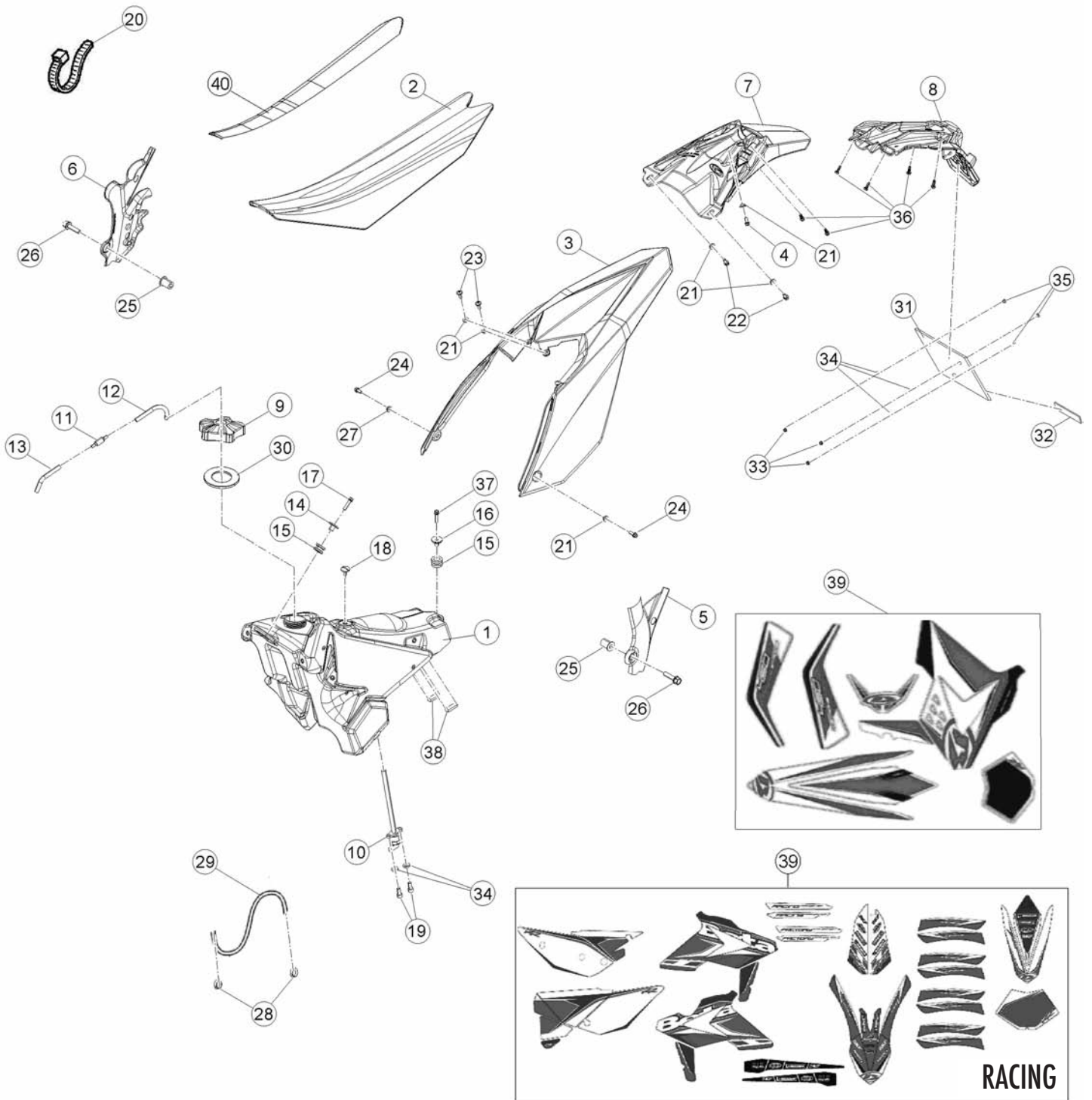

Tav.43B

Pos Loc Ps Pos	Numero Number Numé ro Nú mero Nummer	Q.tà Q.ty Q.té M.ge C.ad	Nota Note Note Nota Anm.	Descrizione	Description	Dé signation	Beschreibung	Descrì cion
1	026430061 051	1		Serbatoio	Fuel tank	Réervoir carburant	Kraftstofftank	Deposito gasolina
2	031430220 000	1		Sella	Seat	Siege	Sattel	Sillin
2	031430380 000	1	RACING	Sella	Seat	Siege	Sattel	Sillin
3	031430301 051	1		Parafango posteriore	Rear mudguard	Garde-boue AR.	Hinterradkotflü gel	Guardabarros tras.
3	031430408 051	1	RACING	Parafango posteriore	Rear mudguard	Garde-boue AR.	Hinterradkotflü gel	Guardabarros tras.
4	1147015 000	1		Bullone M6x12	Bolt M6x12	Boulon M6x12	Bolzen M6x12	Tornillo M6x12
5	020430601 059	1		Protezione telaio Sx	L.H. frame guard	Protection chassis G.	Rahmenschutz Links	Protecció n bastidor izquierda
6	020430611 059	1		Protezione telaio Dx	R.H. frame guard	Protection chassis D.	Rahmenschutz Rechts	Protecció n bastidor derecha
7	020432311 059	1		Portatarga	Plate holder	Porte-plaque	Kenzeichenträ ger	Porta matr.
8	020430341 059	1		Portatarga omologazione	Homologation plate holder	Porte-plaque homologation	Zulassungs Kenzeichenträ ger	Porta matr. Homologació n
9	031430010 000	1		Tappo serbatoio	Filler cap	Bouchon de réervoir	Tankverschluss	Tapó n depó sito
10	020430070 000	1		Rubinetto benzina	Fuel cock.	Robinet melange	Kraftstoffhahn	Grifo mezcla
11	031430050 000	1		Valvola sfiato serbatoio	Reservoir breather valve	Reniflard réervoir	Behä lterentlü ftungsventil	Vá lvula alivio depó sito
12	020430030 000	1		Tubo tappo-valvola sfiato	Plug-Bleeder valve pipe	Tuyau bouchon-soupape purge	Leitung Verschlü ß-Entlü ftungsventil	Tubo tapó n-vá lvula purga de aire
13	020430040 000	1		Tubo valvola sfiato-raccordo	Bleeder valve-union pipe	Tuyau soupape-Raccord purge	Leitung Entlü ftungsventil-anschlu ß	Tubo vá lvula purga de aire-Unió n
14	020430020 000	1		Distanziale mozzo post. Sx	LH rear hub spacer	Entretoise moyeu arriere G.	Distanz re	Distanciadore buje tras. Izq.
15	2891946 000	2		Silentbloc	Silentbloc	Silentbloc	Puffer	Silent-block
16	031430020 000	1		Distanziale	Spacer	Entretoise	Distanzstü ck	Distanciadore
17	1150010 000	1		Bullone M6x25	Bolt M6x25	Boulon M6x25	Bolzen M6x25	Tornillo M6x25
18	3189010 000	1		Vite spec. bloccaggio sella	Seat locking screw	Vis bloccage selle	Schraube	Tornillo bloqueo silli n
19	3129910 000	2		Vite 5x12	Screw 5x12	Vis 5x12	Schraube 5x12	Tornillo 5x12
20	1514264 000	1		Fascetta	Clamp	Collier	Schelle	Abrazadera
21	1354820 000	7		Distanziale 6,5x9,0x13,5	Spacer 6,5x9,0x13,5	Entretoise 6,5x9,0x13,5	Distanzstü ck 6,5x9,0x13,5	Distanciadore 6,5x9,0x13,5
22	1147015 000	2		Bullone M6x12	Bolt M6x12	Boulon M6x12	Bolzen M6x12	Tornillo M6x12
23	3195510 000	2		Vite TBCE M6x12	Screw TBCE M6x12	Vis TBCE M6x12	Schraube TBCE M6x12	Tornillo TBCE M6x12
24	1148025 000	2		Bullone 6x16 ch 8 rs	Bolt 6x16 ch 8 rs	Boulon 6x16 ch 8 rs	Bolzen 6x16 ch 8 rs	Tornillo 6x16 ch 8 rs
25	2733740 000	2		Rivetto filettato M6	Threaded rivet M6	Rivet fileté M6	Niete mit gewinde M6	Remache roscado M6
26	1149070 000	2		Bullone 6x20 ch rs	Bolt 6x20 ch rs	Boulon 6x20 ch rs	Bolzen 6x20 ch rs	Tornillo 6x20 ch rs
27	1362000 000	1		Distanziale	Spacer	Entretoise	Distanzstü ck	Distanciadore
28	C07080080 000	2		Anello stringitubo CE12	Pipe clamping ring CE12	Anneau serre-tube CE12	Schlauchschele CE12	Anillo prensatubo CE12
29	026430050 000	1		Tubo serbatoio-carburatore	Tank-carburettor pipe	Tuyau réervoir-carburateur	Tankleitung-Vergaser	Tubo radiador-carburador
30	031430030 000	1		Guarnizione tappo	Packing for cap	Joint bouchon	Deckeldichtung	Junta tapó n
31	018430101 059	1		Portatarga	Plate holder	Porte-plaque	Kenzeichenträ ger	Porta matr.
32	1233086 000	1		Catadiottro posteriore	Rear reflector	Catadioptré AR.	Rü ckstrahler hinten	Catafaro tras.
33	1311010 000	3		Dado autobloccante M5	Self locking nut M5	Ecrou de sé curité M5	Mutter, selbstsichernd M5	Tuerca de seguridad M5
34	2736000 000	5		Rondella 5x11	Washer 5x11	Rondelle 5x11	U.Scheibe 5x11	Arandela 5x11
35	3129860 000	3		Vite M5x16 TTLIC	Screw M5x16 TTLIC	Vis M5x16 TTLIC	Schraube M5x16 TTLIC	Tornillo M5x16 TTLIC
36	3179960 000	6		Vite autofilettante M6x15	Self tapping screw M6x15	Vis taraud M6x15	Schraube, Blech M6x15	Tornillo autorosc. M6x15
37	1150300 000	1		Bullone 6x30 ch rs	Bolt 6x30 ch rs	Boulon 6x30 ch rs	Bolzen 6x30 ch rs	Tornillo 6x30 ch rs
38	031430040 000	2		Tampone serbatoio	Tank buffer	Silentbloc réervoir	Puffer tank	Silent-block deposito
39	031430738 200	1		Kit decalco completo	Trimnings kit, assy	Jeu enjoliv. Complet	Abziehbildsatz, kpl.	Juego calcom. compl.
39	031430378 200	1	RACING	Kit decalco completo	Trimnings kit, assy	Jeu enjoliv. Complet	Abziehbildsatz, kpl.	Juego calcom. compl.
40	031460040 000	1	RACING	Copertura sella	Saddle cover	Housse de selle	Abdeckung	Cubierta silli n

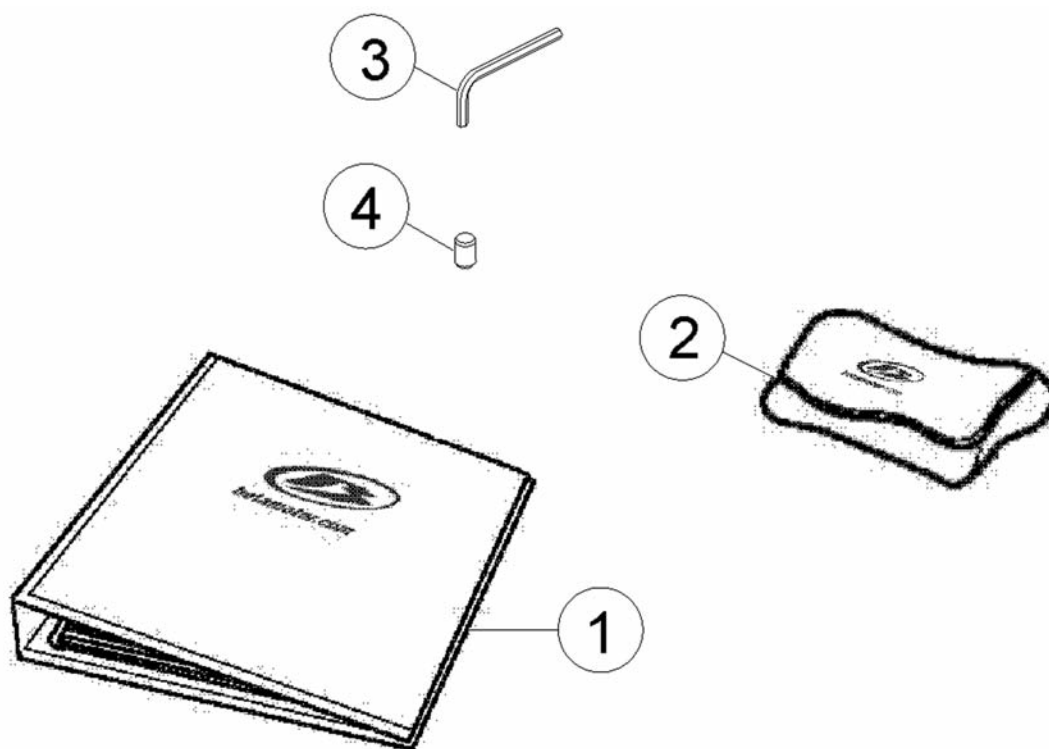

Pos Loc Pos Ps Pos	Numero Number Numéro Número Nummer	Q.tà Q.ty Q.té M.ge C.ad	Nota Note Note Nota Anm.	Descrizione	Description	Dé signation	Beschreibung	Descrìpiò n
1	026440100 000	1		Manuale uso e manutenzione	Owner' s manual	Manuel d' utilisation et entretien	Bedienungs und Wartungshandbuch	Manual de Uso y Manutención
2	020442028 000	1		Borsa attrezzi	Tool roll	Trousse à outils	Werkzeugtasche	Bolsa herramientas
3	020440030 000	1		Chiave a brugola 6mm	Allen wrench 6mm	Clé Allen 6mm	Sechskantschlüssel 6mm	Llave de imbus 6mm
4	020440040 000	1		Bussola 8	Bush 8	Joint 8	Buchse 8	Buje 8





Handwriting practice area consisting of 20 horizontal dotted lines.



